

Operation Manual and Parts Directory

Glas tender®

LC66 PRE MIX, POST MIX AND JUICE PRO DISPENSERS
SPRINT COUNTER TOP DISPENSERS



Post-Mix LC66-6-LEV



Pre-Mix LC66-6-PRE

Glastender, Inc. · 5400 North Michigan Road · Saginaw, MI · 48604-9780
800.748.0423 · 989.752.4275 · Fax 989.752.4444 · www.glastender.com

WARRANTY STATEMENT

APPLICABLE TO ALL PRODUCTS SOLD WITHIN THE UNITED STATES AND CANADA

Glastender, Inc. warrants all products to be free of defects in material and workmanship. One-year labor and parts warranty applies to all glasswashers, self-contained refrigeration models, and BDS model bottle disintegration units. In established areas, a start up is included with GT-24 and GT-30 model glasswashers. Warranty is effective for one year from the date of installation or up to 18 months from date of factory shipment, whichever occurs sooner. Glastender, Inc. will replace any part or assembly found defective under normal use and service.

For warranty labor claims beyond 15 months from the date of factory shipment, proof of date of installation or occupancy must be provided. Authorization for labor must be obtained from Glastender within the warranty period and prior to the service being performed.

Labor warranty applies to the United States and Canada only.

Remote refrigeration models and beer line chillers include a one-year parts warranty only. There is no labor warranty on these products.

Field replacement parts not covered under the original warranty include a 90-day part warranty from the date of installation.

FOUR YEAR ADDITIONAL COMPRESSOR WARRANTY: Glastender will warrant to the original user the compressor for all self-contained refrigeration models for an additional four years following the regular one-year warranty period. This plan applies to the compressor only.

A completed warranty claim form **MUST** accompany all returned defective parts or assemblies. Upon request, a defective part or assembly must be returned to Glastender, Inc., Saginaw, Michigan, with all transportation and delivery charges prepaid. Warranty repairs or replacements will be shipped FOB factory in Saginaw, Michigan. Reimbursement for applicable freight charges covers ground service only.

Glastender provides in-warranty repairs during a service company's regular working days and hours. There is no provision for payment of a premium rate during "overtime" hours. When warranty service is requested during other than normal working hours, the end user will be charged the premium portion of the overtime rate.

The warranty covers substantiated travel expenses for up to 2 hours / 100 miles round trip up to a maximum of \$150. Any additional costs due to installations that require extra work, time, or travel to gain access for service are the sole responsibility of the equipment purchaser. Any exceptions to these travel and access limitations must be pre-approved by a factory representative.

The warranty does not cover door gaskets, chemical tubing, pump squeeze tubing, and/or any equipment subjected to accidents, freight damage, alterations from the original design, improper power and/or plumbing hookups, improper chemical use, general misuse, or lack of routine required maintenance as determined by Glastender, Inc. Installation, normal control adjustments, general maintenance, correcting an installation error, or service calls that reveal the unit is functioning normally will not be reimbursed under warranty.

Condenser coils on self-contained refrigeration products must be cleaned regularly. Failure to provide adequate air flow to a refrigeration unit will void the warranty.

Glastender shall not be liable for loss of use, revenue, or profit, or for any other indirect, incidental, special, or consequential damage including, but not limited to, product spoilage or loss.

This warranty is conditioned upon Glastender receiving notice of any defect subject to this warranty within sixty (60) days of its discovery by the end user or dealer. All products are warranted only for the initial place of installation. Removal of a product automatically terminates this warranty.

SECOND YEAR EXTENDED PARTS & LABOR WARRANTY:

Glastender's one-year parts and labor warranty on self-contained refrigeration units, excluding beer line chillers, can be extended to two years with the purchase of a two year parts and labor warranty. Specify part number EWR2 (\$150 net price) when ordering.

EXPORT WARRANTY - One year parts only.

EXCLUSION OF WARRANTIES

EXCEPT AS PROVIDED ABOVE, GLASTENDER MAKES NO WARRANTIES, EXPRESS OR IMPLIED, INCLUDING, BUT NOT LIMITED TO, ANY IMPLIED WARRANTY OF MERCHANTABILITY, FITNESS FOR A PARTICULAR PURPOSE OR NON-INFRINGEMENT.

LIMITATION OF REMEDIES AND DAMAGES If Buyer makes a valid and timely claim as outlined above, Glastender's liability and Buyer's remedies under this agreement will be limited solely to labor charges authorized and/or replacement or credit, at Glastender's option, with respect to Products returned at Buyer's expense within thirty (30) days after warranty repair. GLASTENDER'S LIABILITY WILL IN NO EVENT BE GREATER IN AMOUNT THAN THE PURCHASE PRICE OF THE RETURNED PRODUCTS. GLASTENDER WILL NOT BE LIABLE UNDER ANY CIRCUMSTANCE FOR CONSEQUENTIAL OR INCIDENTAL DAMAGES, INCLUDING, BUT NOT LIMITED TO, LABOR COSTS EXCEPT AS COVERED UNDER OUR WARRANTY, LOST PROFITS OR THE LOSS OF PERISHABLE PRODUCTS RESULTING FROM THE USE OF OR INABILITY TO USE OUR PRODUCTS OR FROM OUR PRODUCTS' INCORPORATION INTO OR BECOMING A COMPONENT OF ANY OTHER PRODUCT. NEITHER PARTY WILL HAVE ANY NEGLIGENCE OR OTHER TORT LIABILITY TO THE OTHER, OR TO ANY THIRD PARTY, ARISING FROM ANY BREACH OF THIS AGREEMENT.

GOVERNING LAW - JURISDICTION

The terms and conditions of an order are to be governed and construed according to the laws of the State of Michigan, without regard to conflict of laws principles. Buyer hereby consents to the jurisdiction and venue of the courts located in Saginaw County, Michigan.

No representative, distributor, dealer, or any other person is authorized to modify this warranty. This warranty replaces all other written or verbal warranties.

NOTE: Glastender, Inc.'s policy of constant quality improvement means that prices, specifications, and policies are subject to change without notice. Questions regarding this warranty should be directed to Glastender's Warranty Administrator.

04-19-17

IMPORTANT!!

Attention Service Companies

Please review the important warranty information on this page. If you believe a service call should be covered by the factory, please call the factory for authorization between 8AM and 5PM EST, Monday through Friday.

<u>Topic</u>	<u>Page</u>
Installation.....	1
Trouble Shooting	2
Quality Assurance Tips	3
Specifications	4
Wiring Diagram	4
Parts Directory	5-6
Typical Installation Diagram	7
Installation Notes	8

LOCATION

1. Position the dispenser, drill counter for lines to pass through.

REFRIGERATION START-UP

1. Remove top cover and fill water bath..
2. Connect electrical supply.

WATER CONNECTIONS

1. Ensure 1/2" (12.70 mm) main water supply.
2. Reduce to 3/8" (9.525 mm) line to the carb.
3. Reduce to 1/4" (4.35 mm) for sweet water valve.
4. Flush water lines before connecting.

CARBONATOR CONNECTIONS

1. Connect 1/4" (6.35 mm) soda supply line to dispenser.
2. Ensure a minimum 20 p.s.i. (1.4 kp/cm²) differential between gas and water pressure.
3. If there is less than 20 p.s.i. (1.4kp/cm²), install a water pressure regulator.
4. Recommended gas pressure: 80 p.s.i. (5.6 kp/cm²).
5. Connect power upon completion.

GAS CONNECTIONS

1. Mount regulator to wall or cylinder.
2. Connect lines to carb. and syrup tanks.
3. Connect high pressure line to CO2 cylinder.

SYRUP LINE CONNECTIONS

1. Connect syrup supply lines between tanks/BIB and Sprint.

START-UP

1. Turn on water supply to carbonator.
2. Purge air through the relief valve on the carb.
3. Connect electrical supply to the carb.
4. Adjust carb. gas regulator to 90 p.s.i. (5.6 kp/cm²)
5. Operate valves until carb. has cycled several times.
6. Purge holding pressure from syrup tanks.
7. Connect syrup and gas lines to syrup tanks/BIB.
8. Set syrup pressure regulator at 20 p.s.i. (1.4 kp/cm²).

NOTE: Required syrup pressures may vary by product and installation.

TROUBLE SHOOTING THE SODA SYSTEM

<u>CONDITION</u>	<u>CAUSE</u>	<u>REMEDY</u>
1. No soda or water at valve.	(a). Water supply interrupted. (b). Frozen water bath. (c). Valve power interrupted.	(a). Check if valve open. (a). Check water pressure (b). Replace ice bank control. (c). Check electrical circuit.
2. No syrup at valve.	(a). Product tank or BIB connector not in place. (b). Low CO2 gas pressure. (c). Tank dip tube "O" ring.	(a). Re-connect. (b). Replace cylinder. (c). Return tank to bottling plant.
3. No Carbonation.	(a). CO2 gas supply depleted (tank volume gauge in the red). (b). Carbonator unit not operating.	(a). Replace cylinder. (a). Replace cylinder. (b). Consult Service Tech.
4. Product foaming on one valve.	(a). Booster gas pressure too high. (b). Syrup supply almost depleted. (c). Brix too heavy.	(a). Re-adjust. (b). Replace tank or BIB. (c). Adjust brix.
5. Product foaming on all valves.	(a). Booster gas pressure too high. (Common regulator) (b). Product tanks or BIB stored in cold ambient temperature and are absorbing CO2.	(a). Re-adjust. (b). Product tanks or BIB should be stored in room temperature and be stored in room temperature.

TROUBLE SHOOTING THE REFRIGERATION SYSTEM

<u>CONDITION</u>	<u>CAUSE</u>	<u>REMEDY</u>
1. Refrigeration unit not operating.	(a). Power supply interruption. • Blown fuse. • Circuit or area-wide failure. (b). Compressor will not start. • Defective overload protector. • Defective starter relay • Internal motor winding fault (c). Condenser fan not running. (Should operate with compressor) • Wiring connection fault. • Burnt motor winding.	• Replace • Check power plug and outlet. • Check, and replace if necessary. • Check, and replace if necessary. • Replace compressor. • Check circuit and repair. • Replace motor.
2. Refrigeration unit operates but does not cool.	(a). Condenser is plugged with dirt. (b). Freon gas leak, (gauge shows vacuum pressure reading on suction side). (c). Agitator motor not operating (should run continuously). • Shaft jammed. • Wiring connection fault. • Burnt motor windings.	(a). Clean with a brush. (b). Locate and repair. • Adjust alignment. • Check circuit and repair. • Replace motor.
3. Water bath frozen.	• Defective cold control.	• Replace control.
4. Noise in water bath.	• Water level too low in water bath.	• Fill to proper level.

Quality is the key to product acceptance, achieving quality assures product uniformity and customer satisfaction. To ensure that the product you sell is the very best, here are some recommended steps you may wish to follow:

CHECK THE SYRUP RATIO (BRIX)

Carbonated soft drinks are formulated to be mixed at a set syrup-to-water ratio. Please refer to the Flomatic 404 valve specifics which follow this section.

CHECK TEMPERATURE

Carbonated soft drinks must be dispensed at a temperature of 40° F or colder. High temperatures will cause excessive foaming, loss of carbonation, sweeter drink and faster syrup flow.

CHECK ICING (IF ICE IS USED)

Never fill the cup more than one third full with ice. Over icing will dilute the drink causing a weak, flat tasting beverage.

CHECK CARBONATION

A constant supply of CO₂ at the correct pressure will ensure proper quality.

TASTE

Always taste the finished drink before serving the first customer of the day; correct temperature, syrup ratio, icing and carbonation.

ROTATION OF PRODUCT

To ensure the quality of the soft drink syrup, always rotate the stock, using the oldest first. Syrup should be stored in a cool dry area.

SANITATION

At the end of each day, clean the dispensing equipment with hot water and a mild detergent, flushing the drain and wiping down all surfaces. The dispensing nozzles should be cleaned with warm soapy water and rinsed thoroughly, also at the end of each day. **Do not leave valve parts soaking overnight or for extended periods of time - this may cause the parts to discolor and plastic material to deteriorate.**

To ensure optimum refrigeration, the cooling fins (condenser) should be vacuumed or brushed with a light bristle, once every two - three months.

SPECIFICATIONS



Dimensions

- Height - 19.06" (48.41 cm)
- Illumination Add - 3.50" (8.89")
- Width - 18.00" (45.72 cm)
- Depth - 25.75" (65.41 cm)

Max Draw Rate

- 6 oz. drinks 405 @ 4/min
 - 12 oz. drinks 239 @ 2/min
- Based on 40°F (4.4°C) or below
@75°F (23°C) ambient syrup and
incoming water

Electrical

- 115V, 60 Hz, 8 amps
- 230V, 50 Hz, 4.2 amps

Refrigeration

- 1/3 HP lift-out

Ice Bank

- 22lbs (10kg)

Valves

- 4,5, or 6

Recovery

- 3 - 6oz. drinks/minute

Pull Down

- 3.5 Hours

Shipping Weight

- 155 lbs (52.2 kg)

Operating Weight

- 161 lbs (73 kg)

Shipping Cube

- 10.5 cu ft (.297 cu m)

STANDARD FEATURES

- Modular lift-out refrigeration for improved in-field service
- Super-compact, low profile counter dispenser
- Light-weight, roto-molded water bath and drip tray
- Cornelius pre-mix valves (Pre-mix)
- Quick disconnect valves [LEV, SF-1, or UF-1] (Post-mix and Juice Pro)
- Designed for maximum dependability and minimum servicing over the long run
- Available with or without illuminated top sign
- Three to six valves (depending on model) deliver ice cold drinks at 40°F (4.4°C) or below based on an ambient air and incoming water temperature of 75°F (23°C)
- Valve lock out switch standard (Post-mix and Juice Pro)
- Portion control valves are available (Post-mix and Juice Pro)

NOTE: A clearance of 12" should be maintained around unit for maximum air flow and a minimum of 12" above unit for servicing. Compressor failure due to inadequate ventilation will void the warranty.

LC66 WIRING DIAGRAM

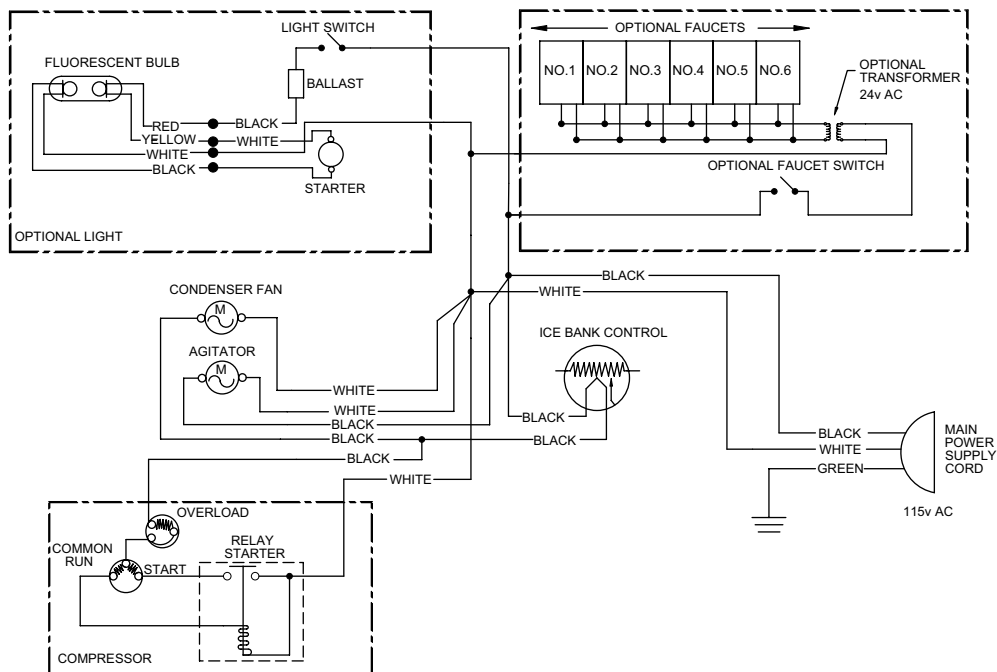

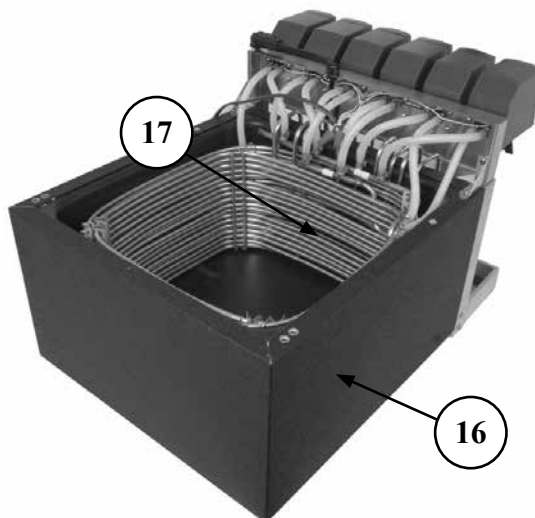
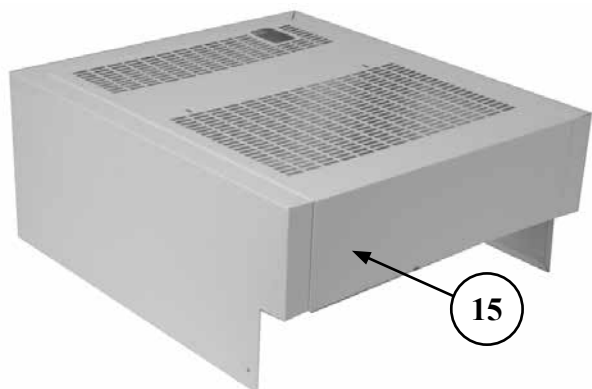
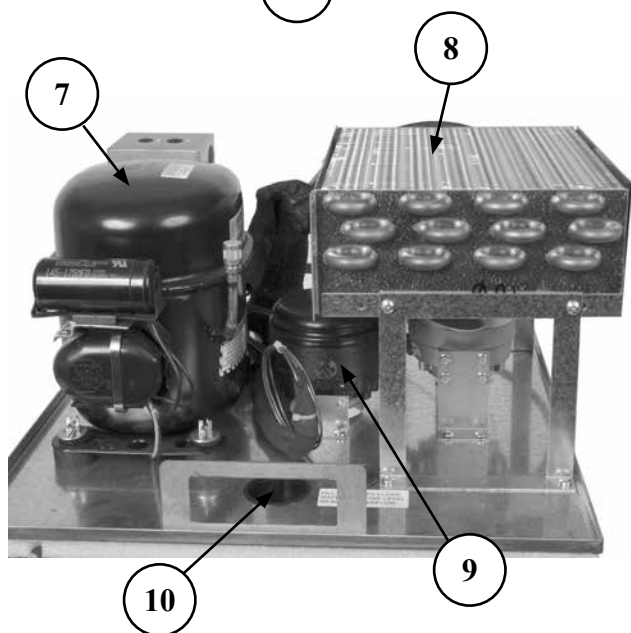
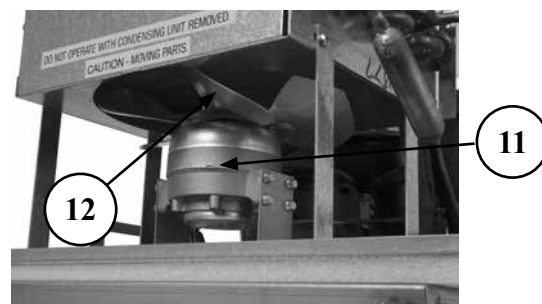
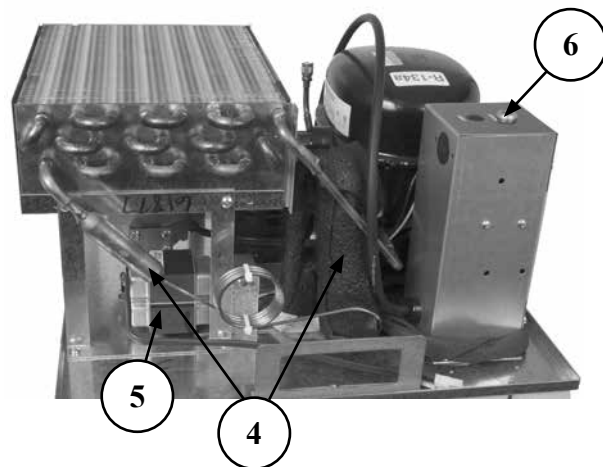
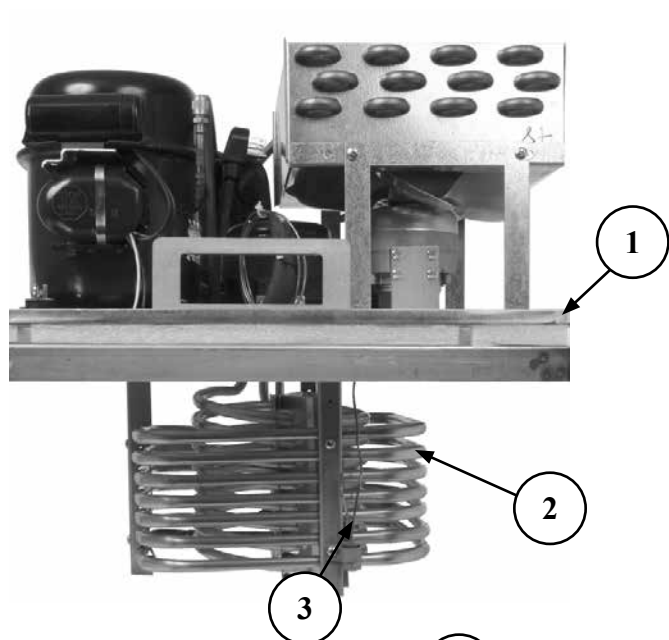

LC66 COMPRESSOR AND RELATED PARTS



<u>PART NO.</u>	<u>OLD PART NO.</u>	<u>DESCRIPTION</u>	<u>PRICE</u>	
1.	09000419	GT-037441	LC 66 Refrigeration Deck Assembly	\$1065.00
2.	09000296	GT-032626	Evaporator Coil	110.00
3.	06007339		Thermostat, 68°, wine, 9530-N1539, replacement	47.00
4.	09000463	GT-041306	Accumulator cap tube assembly w/ dryer	40.00
5.	01000559	GT-034204	Transformer	37.00
6.	09000306	GT-033422	Locking switch	30.53
7.	06001439	GT-035014	Compressor, 1/3 HP	435.00
8.	09000295	GT-032623	Condenser Coil	101.00
9.	09000338	GT-035116	Agitator Motor	170.00
10.	09000436	GT-038497	Plug, black 1 3/4" hole	.50
11.	09000341	GT-035121	Condenser fan motor, 9w	85.00
12.	07000155	GT-032803	Condenser fan blade, 9w motor	12.00
13.	09000106		Cup rest, perforated	25.00
14.		GT-038010	Plastic drain pan	49.22
15.	09000401	GT-036160	Cover, complete, LC66	106.00
16.	09000484	GT-037114	Main cabinet tank, 6 series	120.00
17.		GT-006551	Basket assembly, Sprint LC66	250.00
	09000261	GT-031404	Exterior power cord, 104"	20.00
For replacement valves, please contact our service department				

