

Operation Manual & Parts List

Glastender®

A Family Company Manufacturing In The USA Since 1969

BOTTLE DISINTEGRATION SYSTEM



Glastender, Inc. · 5400 North Michigan Road · Saginaw, MI · 48604-9780
800.748.0423 · 989.752.4275 · Fax 989.752.4444 · www.glastender.com



SAFETY AND GROUNDING INSTRUCTIONS

IMPORTANT SAFETY INSTRUCTIONS

WARNING – When using electric appliances, basic precautions should always be followed, including the following:

- a. Read all the instructions before using the appliance.
- b. To reduce the risk of injury, close supervision is necessary when an appliance is used near children.
- c. Do not contact moving parts.
- d. Only use attachments recommended or sold by the manufacturer.
- e. Do not use outdoors.
- f. – To disconnect, turn all controls to the off (“O”) position, then remove plug from outlet.
 - Do not unplug by pulling on cord. To unplug, grasp the plug, not the cord.
 - Unplug from outlet when not in use and before servicing or cleaning.
 - Do not operate any appliance with a damaged cord or plug, or after the appliance malfunctions or is dropped or damaged in any manner. Return appliance to the nearest authorized service facility for examination, repair, or electrical or mechanical adjustment.
- g. For a grounded appliance – Connect to a properly grounded outlet only. See Grounding Instructions.
- h. To Reduce the Risk of Electric Shock – Connect to a receptacle that is protected by a ground fault circuit interrupter (GFCI).

SAVE THESE INSTRUCTIONS

GROUNDING INSTRUCTIONS

This appliance must be grounded. In the event of malfunction or breakdown, grounding provides a path of least resistance for electric current to reduce the risk of electric shock. This appliance is equipped with a cord having an equipment-grounding conductor and a grounding plug. The plug must be plugged into an appropriate outlet that is properly installed and grounded in accordance with all local codes and ordinances.

DANGER – Improper connection of the equipment-grounding conductor can result in a risk of electric shock. The conductor with insulation having an outer surface that is green with or without yellow stripes is the equipment-grounding conductor. If repair or replacement of the cord or plug is necessary, do not connect the equipment-grounding conductor to a live terminal. Check with a qualified electrician or serviceman if the grounding instructions are not completely understood, or if in doubt as to whether the appliance is properly grounded. Do not modify the plug provided with the appliance – if it will not fit the outlet, have a proper outlet installed by a qualified electrician.

INDEX

<u>Topic</u>	<u>Page</u>
Safety and Grounding Instructions	1
Introduction.....	2
What is a Bottle Disintegration System (BDS)?	2
Utility Requirements and Connections.....	3
Uncrating and Assembly Instructions.....	3
Operating Instructions.....	4
Cleaning Instructions	5 - 6
Wiring Diagram	7
BDS Parts List	8 - 10
Accessories	10
220V Parts List	10
Troubleshooting Guide	11
Terms and Conditions	12
Warranty.....	13

IMPORTANT !! Attention Service Companies IMPORTANT !!

Please review the important warranty information on page 13. If you believe a service call should be covered by the factory, please call the factory for authorization between 8AM and 5PM EST, Monday through Friday.

INTRODUCTION

This manual describes the operational features for the BDS model Bottle Disintegration System. Please review this information before attempting installation and operations. Long term, trouble-free operations will follow if good housekeeping and maintenance procedures are followed. Thank you for selecting Glastender, Inc. products.

WHAT IS A BOTTLE DISINTEGRATION SYSTEM?

It is simply a piece of machinery that crushes or breaks down glass bottles, reducing the area needed to store empty containers and minimizing the volume for disposal purposes. When the ON/OFF switch is on, a motor will run causing the crusher bar to spin rapidly. Glass bottles are introduced into the machine through the bottle chute. When they come in contact with the crusher bar, they are reduced to small pieces of glass called cullet. The cullet falls down the drum and into the bucket in the bottom enclosure of the machine.

For the machine to function normally:

- The bucket must be in place and seated fully in the unit
- The door must be closed
- The covers must be in place
- The crusher bar must be spinning at top speed (allow a minimum of 3 seconds before inserting a bottle)

UTILITY REQUIREMENTS AND CONNECTIONS

Electrical: 120 V single phase, 60 Hz, 9' grounded cord included. A dedicated 15 amp circuit is recommended. Power requirements - 9.0 amps.

UNCRATING AND START-UP INSTRUCTIONS

The BDS is shipped fully assembled in one carton. Refer to photo right to identify the following:

1. Top cover
2. Door
3. Chute opening
4. Baffles
5. Indicator lights and ON/OFF switch
6. Casters

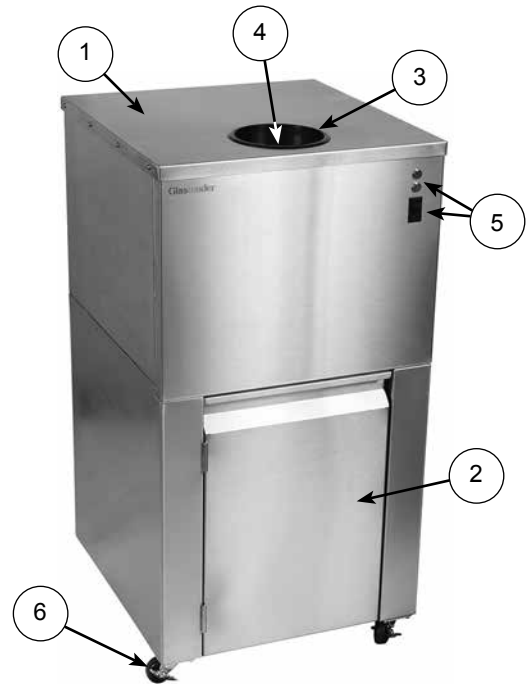

Start-up instructions:

1. Remove all packaging from around the main section.
2. Remove BDS unit from wood pallet and place on a firm, level surface.
3. Remove all plastic protective paper from all stainless steel parts.
4. The BDS must be installed in accordance with local country electrical codes. A standard electrical supply (120VAC only, 60HZ, 9.0A), properly grounded in accordance with the National Electrical Code and local codes and ordinances, is required.
5. Plug in BDS, place in position. BDS unit should be placed up to a wall against the back bumpers (see Figure 1).
6. Lock the front casters, open the door, and assure that the bucket is fully seated in the unit.

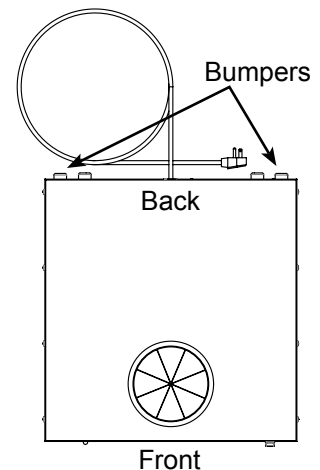

Figure 1



1. Unit must be located on a firm and level surface.
2. A 1/2" clearance above top is required for proper air flow to avoid overheating the motor.
3. Unit must be installed in an area protected from the elements such as rain, water spray, or drips.
4. Unit must NOT be located next to ovens, grills, or other high heat sources.

OPERATING INSTRUCTIONS



1. Do NOT reach into the bottle chute while machine is running and plugged in.
2. Do NOT attempt to un-jam or repair the machine while it is plugged in.
3. Do NOT reach into the drum opening while the machine is running and plugged in.
4. Do NOT place plastic bags in the bucket.
5. Only use bucket supplied.
6. Do NOT place metal caps, plastics, or ceramics into the Bottle Chute.
7. Do NOT put hand into the bucket and into cullet.
8. Only Glastender, Inc. replacement parts should be used. Components from other suppliers may result in machine malfunctions.

Operating instructions:

1. Turn the machine on by toggling the ON/OFF switch. The green light will illuminate to signify the unit is on and running. Wait a minimum of three (3) seconds for the crusher bar to reach maximum speed.
2. Feed a bottle through the top chute opening. A quick thrust is required to get the bottle through the chute baffles. If desired, you may slowly feed one bottle using the next bottle to push it through the chute. **NOTE:** Although it is safe for your fingertips to be inserted through the top rubber baffles, do NOT reach your hand into the bottle chute!
3. Turn the machine off by toggling the ON/OFF switch when done crushing bottles. **NOTE:** If you intend to remove the bucket, wait a minimum of 60 seconds for the glass particles to settle.
4. Periodically remove the bucket to verify fill level to prevent overflowing.

If the red light is on, turn the machine off and check the following:

1. *Is the bucket properly in place?* Security feature: the unit will not operate when the bucket is not in place. With the bucket handle facing out, move the bucket in place and properly seat into the unit.
2. *Is the door closed?* Security feature: the unit will not operate if the door is open. Close the door completely.

NOTE: For additional assistance please refer to the Trouble Shooting Guide on page 11.

CLEANING INSTRUCTIONS

General Cleaning and Care Instructions for Stainless Steel:

IMPORTANT: Always follow label instructions on cleaning products. Soap, water and a soft cloth or sponge are suggested first unless otherwise noted.

Stainless steel will stain or rust if not cared for properly. Please pay attention to the following guidelines:

- 1. Use the proper tools** – Use non-abrasive tools, such as a soft cloth or plastic cleaning pad. NEVER use steel wool pads, soap filled scouring pads, abrasive cleaners, cleaners containing chlorine, Cooktop Polishing Creme, or gritty washcloths.
- 2. Clean with the polish lines** – Always scrub in a direction that is parallel to the grain or lines in the stainless steel.
- 3. Clean regularly** – Make cleaning easier by doing so frequently to avoid build-up of hard, stubborn stains. Use alkaline, alkaline chlorinated, or non-chloride containing cleaners.
- 4. Rinse and wipe** – Anytime chemicals are used to clean stainless steel, make sure to rinse afterward with clean water and wipe away any standing water.
- 5. Never use hydrochloric acid (muriatic acid) on stainless steel.**

Recommended cleaners for specific situations:

Stainless steel needs to be cleaned for aesthetic considerations and to preserve corrosion resistance. Stainless steel actually thrives with frequent cleaning, and, unlike some other materials, it is impossible to “wear out” stainless steel by excessive cleaning.

Routine cleaning - Use warm water, liquid detergent, ammonia, or all-purpose cleaner. Apply with soft cloth or sponge. Rinse with clean water and dry with a soft cloth.

Food spills - *Clean Immediately.* Use a stainless steel cleaner and polish. Apply with a soft cloth or sponge.

Fingerprints and smears - Use a stainless steel cleaner and polish or glass cleaner. Apply with a soft cloth or sponge.

Hard water spots - Remove with vinegar. Apply with a soft cloth or sponge.

Daily Cleaning:

1. Turn off unit. Wait 60 seconds before opening door.
2. Open door, remove bucket, and empty cullet.
3. Replace bucket and shut door.
4. Clean outside of unit per General Cleaning and Care Instructions for Stainless Steel above.
5. Use a damp cloth to wipe down the top rubber gasket of the bottle chute.

CLEANING INSTRUCTIONS

Odor Control Cleaning:

Use one or a combination of the following steps as needed to control odor.

A. Introduce a multipurpose, water-soluble, malodor counteractant, such as Disappear® by Franklin Maintenance Products. Note: NEVER use chlorine.

1. Pour a few drops of malodor counteractant down the chute opening or pour some in a bottle prior to crushing.

B. Clean interior surfaces:

1. Turn off unit. Wait 60 seconds before opening door.
2. Open door, remove bucket, and empty cullet.
3. Rinse out bucket with hot, soapy water.
4. Vacuum out interior of bottom enclosure.
5. Clean interior of unit per General Cleaning and Care Instructions for Stainless Steel, page 5.
6. Replace bucket and shut door.

C. Clean bottle chute (NOTE: Reference page 8 for bottle chute assembly diagram):

1. Unplug unit.
2. Remove Top Cover by removing eight (8) screws and lifting off the top cover.
3. To clean the bottle chute:
 - a. Disconnect the safety switch.
 - b. Remove the eight (8) screws and nuts (4 each) for Top Cover of Bottle Chute to Small Tube Weldment and for Small Tube Weldment to Large Tube Weldment.
 - c. Remove the rubber and plastic gaskets and wash with warm, soapy water.
 - d. CAUTION: Do NOT get electrical components wet! Clean per General Cleaning and Care Instructions for Stainless Steel, page 5.
 - e. Re-assemble bottle chute. Note: The middle plastic gasket must be oriented with the star pattern offset of the star pattern of the rubber gasket.
 - f. Re-connect safety switch.
4. Replace top cover and re-install eight (8) screws.
5. Plug in unit.

WIRING DIAGRAM

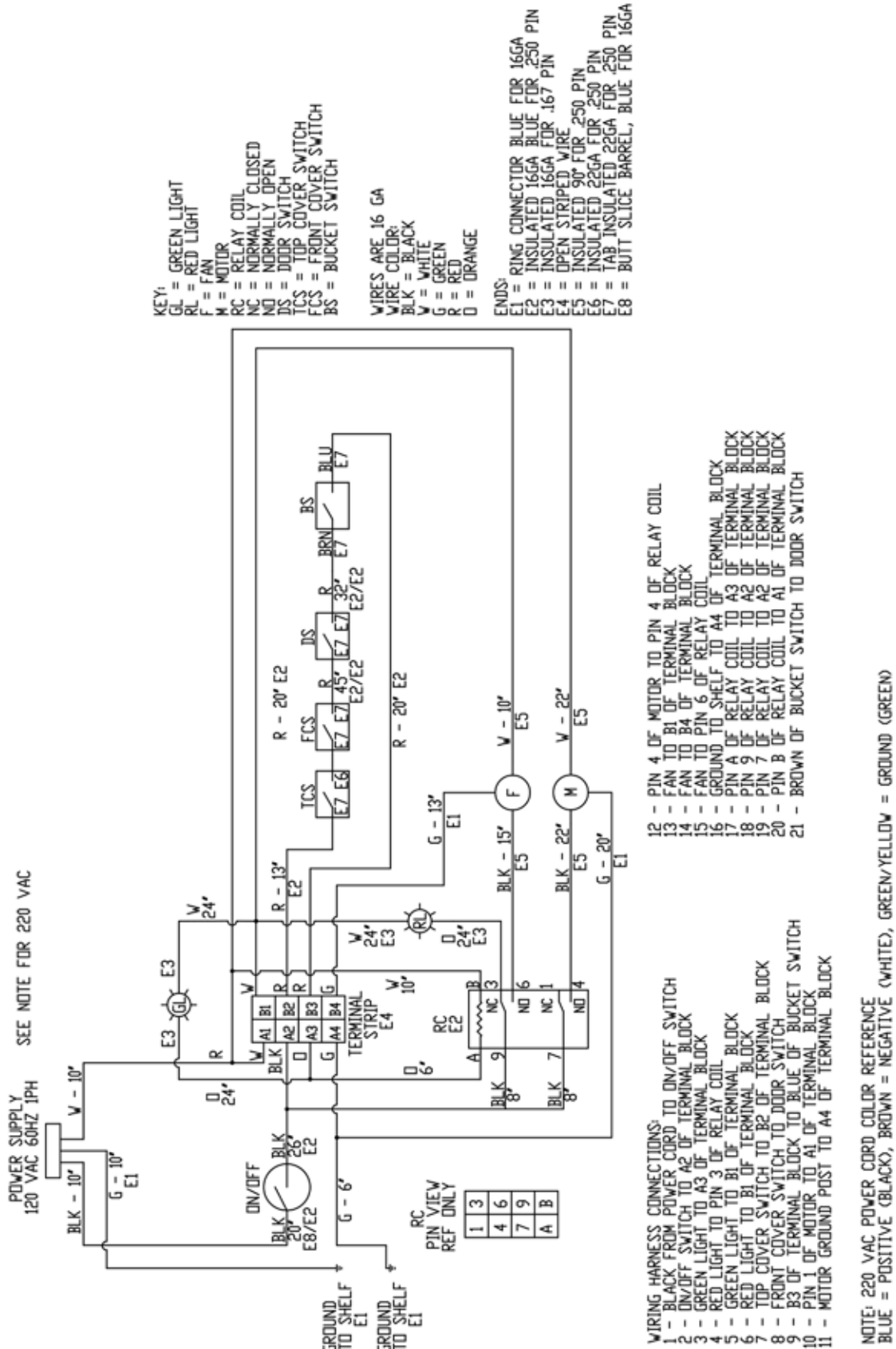

BDS PARTS LIST

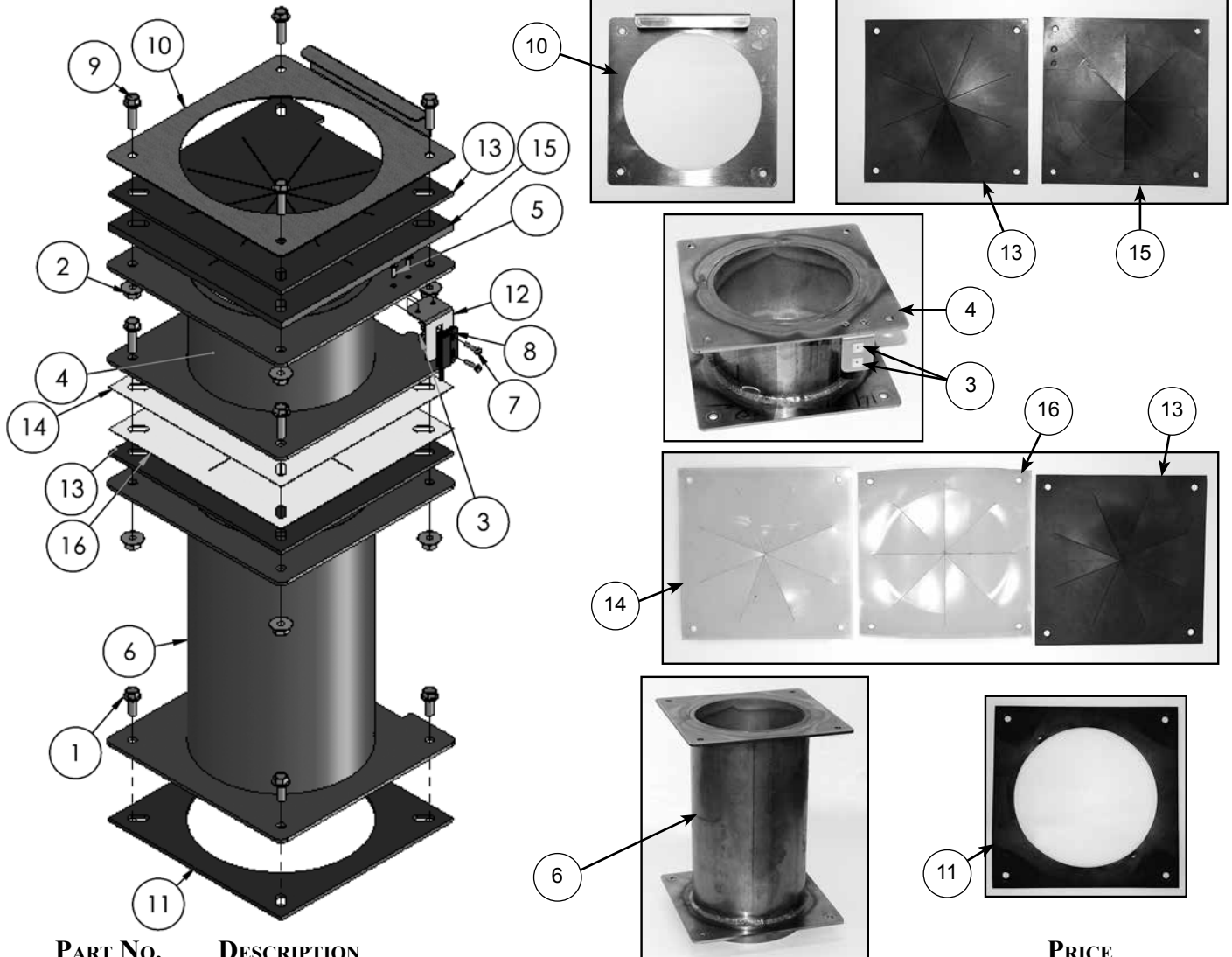

PART NO. **DESCRIPTION**

PRICE

1.	0000041	Screw, 1/4-20 x 5/8", whiz lock, zinc (Qty. 4 required)	.50 each
2.	01000623	Nut, 1/4"-20, large flange serrated nut (Qty. 8 required)	.50 each
3.	00000257	Grommet, screw, plastic	.50 each
4.	14000095	Chute assembly, short, BDS	118.00
5.	00000178	Pop rivet, stainless 1/8" steel	1.00
6.	14000066	Tube weldment, long, BDS	158.00
7.	14000062	Screw, 4 x 0.5 pan head, sms, ss	.50 each
8.	01001428	Sensor, magnetic switch	11.00
9.	00000283	Screw, 1/4-20 x 7/8" whiz lock, zinc (Qty. 8 required)	.50 each
10.	14000013	Chute, top flange	28.00
11.	14000081	Gasket, rubber, 1/8" thick, tube bottom	13.00
12.	14000012	Bracket, mag. sensor, chute	2.00
	14000122	Baffle kit, consisting of part #14000020 (2), 14000022, 14000019 and 14000021)	67.00
13.	14000020	Baffle, rubber, 1/8" thick, star angled (Qty. 2 required)	13.00 each
14.	14000022	Baffle, plastic liner, star angled	8.00
15.	14000019	Baffle, Rubber, 1/4" thick star straight	25.00
16.	14000021	Baffle, plastic liner, star straight	8.00

BDS PARTS LIST

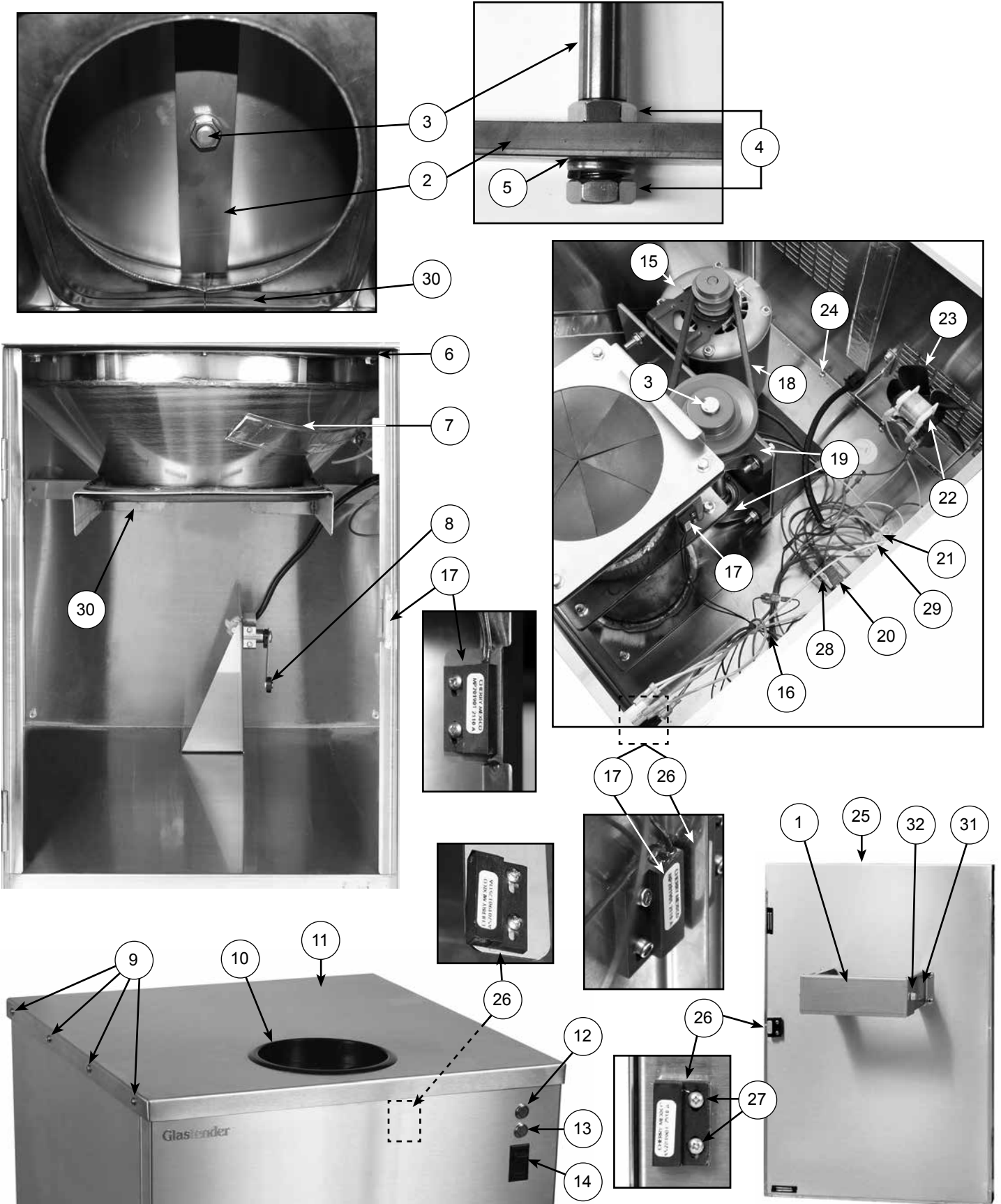

BDS PARTS LIST

<u>PART NO.</u>	<u>DESCRIPTION</u>	<u>PRICE</u>
1. 14000128	Bucket seating bar	4.00
2. 14000034	Crusher bar cr bar hardened	100.00
3. 14000032	Drive shaft bar	96.00
4. 14000060	Nut, 5/8-11 hex jam stainless steel	3.00 each
5. 14000061	Washer, 5/8 lock stainless steel	1.00 each
6. 14000044	Rubber gasket, drum	99.00
7. 14000072	Drum assembly, BDS	546.00
8. 14000129	Limit switch, bucket presence	140.00
9. 00000039	Screw, 10-32 x 3/8", phillips, truss head, machine, stainless steel	.50 each
10. 03003291	Grommet, 6", black	14.00
11. 14000068	Top cover assembly, BDS (magnetic actuator not included)	150.00
12. 01000591	Light, power, green, 240VAC	11.00
13. 07000171	Light, fault indicator, red, 125V	10.00
14. 01000549	Switch, on/off	18.00
15. 14000039	Motor, 1/3HP 60HZ, 115V	345.00
16. 14000092	Wire harness	78.00
17. 01001428	Sensor, magnetic switch (3 on unit - top locator, door closed, front cover to side cover)	11.00 each
18. 14000038	Belt (drive) 1/2" x 24"	15.00
19. 14000040	Drive shaft bar mount (pillow block, with bearing)	52.00
20. 14000043	Relay, controller, 120V, 20A, 8 pm	64.00
21. 09000615	Terminal strip, 4-pole 50 amp 300V 18-8 AWG	10.00
22. 06001445	Motor, cooling fan, 120V	45.00
23. 09000298	Cooling fan blade, 5 blade, black	5.00
24. 00000153	Screw, phillips pan head, #3 self drilling, 10 x 1/2, 410 stainless steel	2.00 each
25. 14000069	Door assembly, BDS (magnetic actuator and door bar not included)	266.00
26. 01001429	Actuator, magnetic (3 on unit - top locator, door closed, front cover to side cover)	11.00 each
27. 14000062	Screw, 4x.50, phillips, pan head, sms, ss	.50 each
28. 14000063	Screw, 4 x .375 phillips pan head, sms, ss	.50 each
29. 14000064	Screw, 4 x .75 phillips pan head, sms, ss	.50 each
14000053	Bucket, 4-gallon, square	27.00
30. 14000120	Bulb seal, bucket	23.00
31. 14000211	Bucket seating bar side bracket	3.50
32. 00000073	Bolt, 1/4"-2 X 3/8"	.50 each

220V PARTS LIST

<u>PART NO.</u>	<u>DESCRIPTION</u>	<u>PRICE</u>
01000591	Light, power, green, 240VAC	11.00
14000084	Motor, 1/3 HP 60 HZ, 115/208-230V	628.00
14000094	Motor, 1/3 HP 50 HZ, 110/208-220V	700.00
14000085	Contact Relay, 240 V, 20A, 8 pin, BDS	58.00
14000086	Light, red, 240V	12.00
06001448	Motor, Fan, 220V, 1300 RPM	57.00

TROUBLESHOOTING GUIDE

PROBLEM	CAUSE	REMEDY
Unit does not run.	<ol style="list-style-type: none"> 1. The door is open. 2. The bucket is not seated fully in the unit. 3. The bucket handle is not facing out. 4. The top cover is not on the machine. 5. The chute is not installed correctly on the unit. 6. The front cover is not on the machine. 7. The unit is unplugged. 8. The ON/OFF switch is in the OFF position. 9. The circuit breaker is tripped. 	<ol style="list-style-type: none"> 1. Close the door. 2. Install the bucket fully into the unit. 3. Remove the bucket and re-install with the handle facing out. 4. Install the top cover. 5. Install the chute as shown on page 8. 6. Install the front cover. 7. Plug the unit into the appropriate power source. 8. Toggle the ON/OFF switch to the ON position. 9. Reset the breaker.
Unit is on but the bar is not turning.	<ol style="list-style-type: none"> 1. A bottle or piece of glass or foreign material is jammed in the chute or drum. 	<ol style="list-style-type: none"> 1. While wearing protective gloves, unplug unit, remove bucket, and reach into drum. Grasp crusher bar and rotate counter-clockwise. This should dislodge any material.
Unit is on but the bar is not turning and there are no motor sounds.	<ol style="list-style-type: none"> 1. The motor has turned off on thermal overload due to excessive heat which is caused by inadequate ventilation or high ambient temperature (i.e., room temperature at 100°F or more). 	<ol style="list-style-type: none"> 1. Turn unit off, wait approx. 30 minutes and turn on again. In all cases, to minimize these events, allow ventilation space on sides and back of unit for adequate circulation of air flow.
Unit is on, motor is running, but bottles are falling through without being crushed.	<ol style="list-style-type: none"> 1. The Crusher bar is jammed. 2. The drive belt has broken. 	<ol style="list-style-type: none"> 1. Un-jam the bar - While wearing protective gloves, unplug unit, remove bucket, and reach into drum. Grasp crusher bar and rotate counter-clockwise. 2. Obtain a new belt. Unplug the unit, remove the top cover, replace belt. Re-install top cover.

TERMS AND CONDITIONS

PRICES:

All prices are LIST. Applicable taxes will be added.

QUOTATIONS:

Unless otherwise stated, quotations are effective for 30 days only.

ACCEPTANCE:

All orders are subject to acceptance by Glastender, Inc.'s headquarters in Saginaw, Michigan. Possession of the Product Directory and Price List is not an offer to sell.

SHIPMENTS:

F.O.B. factory in Saginaw, Michigan. Freight terms are Third Party or Collect if shipped directly to you. Prepay and Add to Invoice freight terms are available upon request. The approximate shipping weights of all products are listed with the prices. Partial shipments will be made unless otherwise specified by the customer. Surface freight classifications are:

- Glasswashers - Class 125
- All Underbar Equipment (including Bar Die) – Class 150
- Portable Bars - Class 150
- Remote refrigerators (i.e., no compressor) or dry storage back bar equipment - Class 125
- Self-contained refrigeration equipment - Class 150
- Ice Display Units (IDU and GDU) - Class 85
- Lighted Liquor Displays - Class 85
- Beer line chillers and beer towers (beverage dispensing equipment) - Class 92.5
- Bottle Disintegration System - Class 150
- Ice Cream Freezers - Class 77.5

All small items are evaluated to see the most cost effective means for shipment. Many small items ship via UPS or FedEx; however, when dimensional weight is excessive, LTL carriers are the most cost effective choice. Spare parts orders received before 1:00 PM EST can usually be shipped the same day.

The order department is happy to assist with routing or shipping questions.

PAYMENT TERMS:

Cash should be included with all orders unless credit terms have been arranged. To establish credit, banking and trade references are required. A convenient credit application is available upon request. Payment via credit card is not our normal means of receiving payment. Visa and MasterCard will be accepted, but must be charged at the time of shipment. In addition, a payment via credit card for orders totaling more than \$500 will incur a 3% convenience fee on the total transaction amount.

DELIVERY:

The majority of equipment is manufactured to order and typically ships within three to six weeks after complete order information is received by the factory. In-stock equipment typically ships within two to three days of the factory receiving complete order information.

RETURNS:

Items specified as "Manufactured to Order" are NOT returnable.

A Return Authorization number must be issued by the factory in advance for any items that are returnable. The number MUST be noted on the outside of the returned package. Returns must be received within 90 days of the issue date. Shipping charges must be prepaid. A minimum 20% restocking charge will be applied to all authorized returns if received in new, unused condition in the original packaging.

The above conditions apply to spare part returns, except spare part returns must be received within 30 days of original shipment for electronic or electrical parts or within 90 days for all other parts.

LOSS OR DAMAGE:

For customer routed shipments, Glastender, Inc. is not responsible for any loss, damage, or delay of merchandise during shipment. Such transit claims must be filed with the carrier. Merchandise must be examined on arrival. If shortages occur, Glastender, Inc. must be notified in writing within five (5) days of delivery to honor any shortage claim. Glastender will assume responsibility for freight claims on Prepay and Add shipments but the customer must inspect freight and note any damage upon receipt. Failure to do so may result in losses at the customer's expense.

CUSTOM ORDERS:

Custom orders must be paid in advance and are not subject to cancellation.

LAMINATES:

Some products include common, readily available plastic laminates of the customer's selection. There may be an additional charge if uncommon varieties are ordered.

07/21/16

WARRANTY STATEMENT

APPLICABLE TO ALL PRODUCTS SOLD WITHIN THE UNITED STATES AND CANADA

Glastender, Inc. warrants all products to be free of defects in material and workmanship. One-year labor and parts warranty applies to all glasswashers, self-contained refrigeration models, and BDS model bottle disintegration units. In established areas, a start up is included with GT-24 and GT-30 model glasswashers. Warranty is effective for one year from the date of installation or up to 18 months from date of factory shipment, whichever occurs sooner. Glastender, Inc. will replace any part or assembly found defective under normal use and service.

For warranty labor claims beyond 15 months from the date of factory shipment, proof of date of installation or occupancy must be provided. Authorization for labor must be obtained from Glastender within the warranty period and prior to the service being performed.

Labor warranty applies to the United States and Canada only.

Remote refrigeration models and beer line chillers include a one-year parts warranty only. There is no labor warranty on these products.

Field replacement parts not covered under the original warranty include a 90-day part warranty from the date of installation.

FOUR YEAR ADDITIONAL COMPRESSOR WARRANTY: Glastender will warrant to the original user the compressor for all self-contained refrigeration models for an additional four years following the regular one-year warranty period. This plan applies to the compressor only.

A completed warranty claim form **MUST** accompany all returned defective parts or assemblies. Upon request, a defective part or assembly must be returned to Glastender, Inc., Saginaw, Michigan, with all transportation and delivery charges prepaid. Warranty repairs or replacements will be shipped FOB factory in Saginaw, Michigan. Reimbursement for applicable freight charges covers ground service only.

Glastender provides in-warranty repairs during a service company's regular working days and hours. There is no provision for payment of a premium rate during "overtime" hours. When warranty service is requested during other than normal working hours, the end user will be charged the premium portion of the overtime rate.

The warranty covers substantiated travel expenses for up to 2 hours / 100 miles round trip up to a maximum of \$150. Any additional costs due to installations that require extra work, time, or travel to gain access for service are the sole responsibility of the equipment purchaser. Any exceptions to these travel and access limitations must be pre-approved by a factory representative.

The warranty does not cover door gaskets, chemical tubing, pump squeeze tubing, and/or any equipment subjected to accidents, freight damage, alterations from the original design, improper power and/or plumbing hookups, improper chemical use, general misuse, or lack of routine required maintenance as determined by Glastender, Inc. Installation, normal control adjustments, general maintenance, correcting an installation error, or service calls that reveal the unit is functioning normally will not be reimbursed under warranty.

Condenser coils on self-contained refrigeration products must be cleaned regularly. Failure to provide adequate air flow to a refrigeration unit will void the warranty.

Glastender shall not be liable for loss of use, revenue, or profit, or for any other indirect, incidental, special, or consequential damage including, but not limited to, product spoilage or loss.

This warranty is conditioned upon Glastender receiving notice of any defect subject to this warranty within sixty (60) days of its discovery by the end user or dealer. All products are warranted only for the initial place of installation. Removal of a product automatically terminates this warranty.

SECOND YEAR EXTENDED PARTS & LABOR WARRANTY:

Glastender's one-year parts and labor warranty on self-contained refrigeration units, excluding beer line chillers, can be extended to two years with the purchase of a two year parts and labor warranty. Specify part number EWR2 (\$150 net price) when ordering.

EXPORT WARRANTY - One year parts only.

EXCLUSION OF WARRANTIES

EXCEPT AS PROVIDED ABOVE, GLASTENDER MAKES NO WARRANTIES, EXPRESS OR IMPLIED, INCLUDING, BUT NOT LIMITED TO, ANY IMPLIED WARRANTY OF MERCHANTABILITY, FITNESS FOR A PARTICULAR PURPOSE OR NON-INFRINGEMENT.

LIMITATION OF REMEDIES AND DAMAGES

If Buyer makes a valid and timely claim as outlined above, Glastender's liability and Buyer's remedies under this agreement will be limited solely to labor charges authorized and/or replacement or credit, at Glastender's option, with respect to Products returned at Buyer's expense within thirty (30) days after warranty repair. GLASTENDER'S LIABILITY WILL IN NO EVENT BE GREATER IN AMOUNT THAN THE PURCHASE PRICE OF THE RETURNED PRODUCTS. GLASTENDER WILL NOT BE LIABLE UNDER ANY CIRCUMSTANCE FOR CONSEQUENTIAL OR INCIDENTAL DAMAGES, INCLUDING, BUT NOT LIMITED TO, LABOR COSTS EXCEPT AS COVERED UNDER OUR WARRANTY, LOST PROFITS OR THE LOSS OF PERISHABLE PRODUCTS RESULTING FROM THE USE OF OR INABILITY TO USE OUR PRODUCTS OR FROM OUR PRODUCTS' INCORPORATION INTO OR BECOMING A COMPONENT OF ANY OTHER PRODUCT. NEITHER PARTY WILL HAVE ANY NEGLIGENCE OR OTHER TORT LIABILITY TO THE OTHER, OR TO ANY THIRD PARTY, ARISING FROM ANY BREACH OF THIS AGREEMENT.

GOVERNING LAW - JURISDICTION

The terms and conditions of an order are to be governed and construed according to the laws of the State of Michigan, without regard to conflict of laws principles. Buyer hereby consents to the jurisdiction and venue of the courts located in Saginaw County, Michigan.

No representative, distributor, dealer, or any other person is authorized to modify this warranty. This warranty replaces all other written or verbal warranties.

NOTE: Glastender, Inc.'s policy of constant quality improvement means that prices, specifications, and policies are subject to change without notice. Questions regarding this warranty should be directed to Glastender's Warranty Administrator.

04-19-17

IMPORTANT!!

Attention Service Companies

Please review the important warranty information on this page. If you believe a service call should be covered by the factory, please call the factory for authorization between 8AM and 5PM EST, Monday through Friday.