

Project: _____	AIA# _____
Item #: _____ Qty: _____	SIS# _____
Model #: _____	

24" X 24" Undercounter Refrigerator

UCR24S-L, UCR24S-R, UCR24X-L, UCR24X-R



Standard Features

- Self-contained with six-foot grounded cord and plug
- All stainless steel interior construction with radius corners for easy cleaning
- Stainless steel exterior front, top and sides
- Special rear recess designed to accommodate outlet behind unit and still maintain 24" depth
- CFC free foamed-in-place insulation
- Digital thermostat control with automatic defrost
- Automatic condensate evaporator
- Includes four 2" casters for an overall height of 34"
- Door lock and interior LED lighting standard
- Available with door hinged left or right, specify suffix '-L' or '-R', respectively
- Available with stainless door (UCR24S) or stainless glass door (UCR24X)



4004503
 Conforms to NSF/ANSI STD 7
 and UL STD 471
 Certified to CSA STD C22.2 No. 120
 Meet NSF 7 requirements
 for open food storage

Specifications

Electrical

- 120V, 1 phase, 60 Hz, 3.0 full load amps
- Dedicated 15 amp circuit is required
- Includes a 6 foot NEMA 5-15P grounded cord and plug

Refrigeration

- 1/8 HP, R134a refrigerant
- 1,228 BTU/hr heat rejection
- Operating range 34°F (1°C) to 40°F (4°C)



Plumbing

- Automatic condensate evaporator. No drain connection required

Shelving

- Two adjustable coated shelves included

Casters

- Four 2" casters. The two front casters are locking

Storage Capacity

- 3.41 cubic feet

Materials

- Stainless steel parts include: interior, door, exterior front, top and sides, hinge and hinge bracket
- Galvanized steel parts include: exterior back and bottom

Dimensional Information

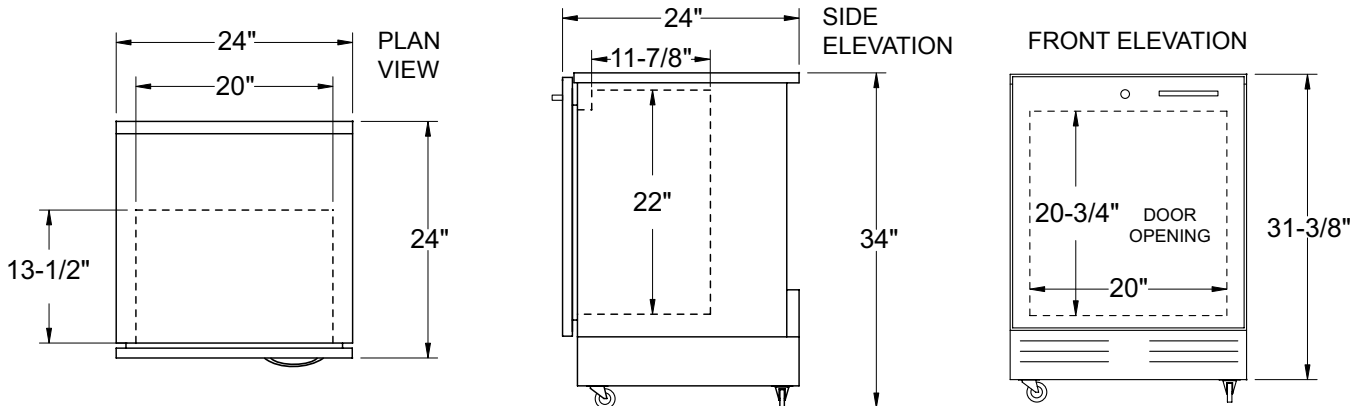

Glastender, Inc. • 5400 North Michigan Road • Saginaw, MI • 48604-9780 989.752.4275 • 800.748.0423 • Fax 989.752.4444 www.glastender.com	Approval/Notes:
Specifications subject to change without notice. For current specifications please visit our website.	