

| | |
|--------------------------|------------|
| Project: _____ | AIA# _____ |
| Item #: _____ Qty: _____ | SIS# _____ |
| Model #: _____ | |

Mobile Ice Cream Freezer

FRM-2



FRM-2



Intertek 4004503 **Intertek**
 Conforms to NSF/ANSI STD 7 and UL STD 471
 Certified to CSA STD C22.2 No. 120

Standard Features

- All stainless steel exterior with 16 gauge galvanized steel exterior bottom.
- Completely integrated design - not just a cabinet with separate drop-in module
- All stainless steel interior liner with radius corners for easy cleaning
- One-piece, seamless top
- Includes four 3" casters, with two locking casters
- CFC free foamed-in-place insulation
- Six foot grounded cord and plug provided, exits at rear
- Designed to accommodate outlet behind unit and still sit flush against the wall
- Holds two 3-gallon containers

| | |
|-----------------------|--------------------------------|
| Specifications | Dimensional Information |
|-----------------------|--------------------------------|

Capacity

- Two 3-gallon containers

Electrical

- 120V, 1 phase, 60 Hz, 4.75 full load amps
- Dedicated 15 amp circuit is recommended
- Includes 6 foot NEMA 5-15P grounded cord and plug



Refrigeration

- Operating range -5°F (-20°C) to 10°F (-12°C)
- 1/4 HP, R404A refrigerant
- 1,945 BTU/hr heat rejection

Casters

- Four 3" heavy duty rubberized casters
- The two server side casters are locking

Materials

- Stainless steel parts include: all components unless otherwise noted
- Galvanized steel parts include: cabinet floor, condensing unit floor, and base channels

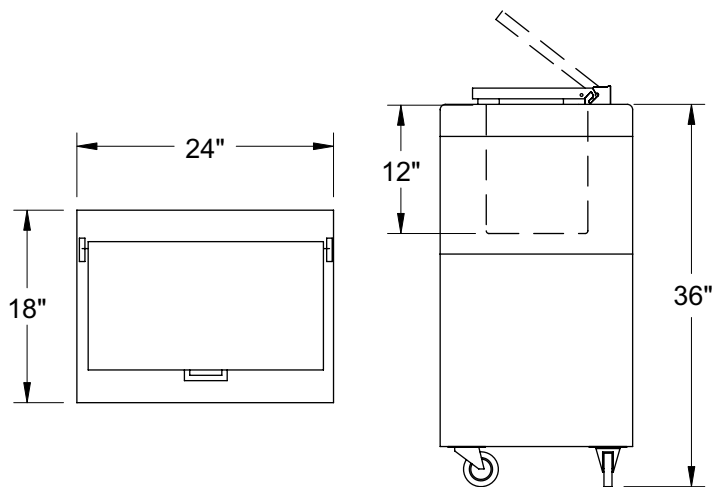

PLAN VIEW

SIDE ELEVATION

To view underbar installation instructions, please visit: http://www.glastender.com/PDF/F-750-165_Underbar_Installation_Instructions.pdf
 To view cleaning and care instructions, please visit: http://www.glastender.com/PDF/F-423-011_ss_clean_care.pdf

| | |
|---|-----------------|
| Glastender, Inc. • 5400 North Michigan Road • Saginaw, MI • 48604-9780 989.752.4275 • 800.748.0423 • Fax 989.752.4444 www.glastender.com | Approval/Notes: |
| Specifications subject to change without notice. For current specifications please visit our website. | |