

Project: _____	AIA# _____
Item #: _____ Qty: _____	SIS# _____
Model #: _____	

Reach-in Mug Frosters One & Two Door Self-contained

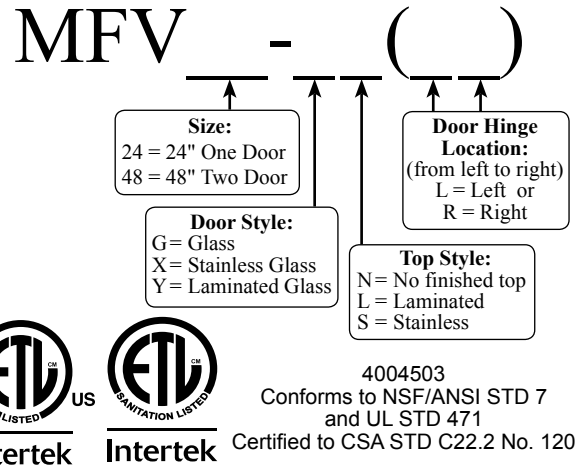

Standard Features

- Self-contained high capacity refrigeration system
- Digital thermostat control with automatic defrost is easily visible
- Two Defrost Cycles:
 1. Automatic - occurs every eight hours without affecting normal operation
 2. Manual - user initiated button for complete six-hour defrost with automatic restart
- Removable refrigeration module for easy maintenance
- All stainless steel interior
- Bottom rack and two adjustable shelves per door
- Includes LED interior lights with on/off switch
- Completely front venting - can be built into a back bar or used as a free standing unit
- Available without a finished top for integrated installation below customer supplied bar top
- Stainless steel sides
- Automatic condensate evaporator
- Foamed-in-place insulation
- Front of cabinet is electrically heated
- Stainless steel die cast handle with lock
- 180° swinging doors
- Optional 3-3/4" casters or 6" legs are available
- Includes triple pane, low E, Argon filled glass door(s)

Specifications

- Electrical**
- 120V, 1 phase, 60 Hz, 7.1 full load amps
 - Dedicated 15 amp circuit is required
 - Includes a 6 foot NEMA 5-15P grounded cord and plug which exits the back of refrigeration compartment
- Refrigeration**
- 1/3 HP, R404A refrigerant
 - Heat rejection - 2907 BTU/Hr
 - Operating range: 12°F (-11°C) to 35°F (2°C)
 - Fin & tube evaporator with forced air circulation
 - Equipped with manual fast freeze mode that accelerates the freezing process and automatically reverts back to the normal operating mode
- Plumbing**
- Automatic condensate evaporator. No drain connection required
- Shelving**
- Bottom rack and two shelves included



- Capacity**
- 10-oz mugs: MFV24 - 108, MFV48 - 252
 - 6" high pint glass: MFV24 - 75, MFV48 - 180
- Legs**
- Optional 6" legs, specify accessory #CLS-4
 - 1-5/8" diameter
 - Stainless steel bullet feet
- Materials**
- Stainless steel parts include: interior, front of cabinet, exterior sides, hinges, hinge and lock brackets, and optional legs
 - Black vinyl-clad steel parts include: standard doors and compressor cover
 - Galvanized steel parts include: exterior sub-top, back and bottom
 - Zinc plated CR steel parts include: leg sockets

Glastender, Inc. • 5400 North Michigan Road • Saginaw, MI • 48604-9780 989.752.4275 • 800.748.0423 • Fax 989.752.4444 www.glastender.com	Approval/Notes:
--	-----------------

Reach-In Mug Froster

Dimensional Information

MFV24

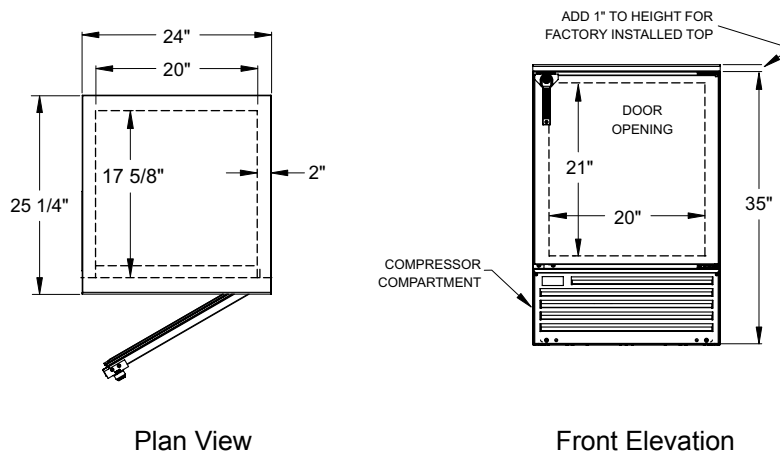

MFV48

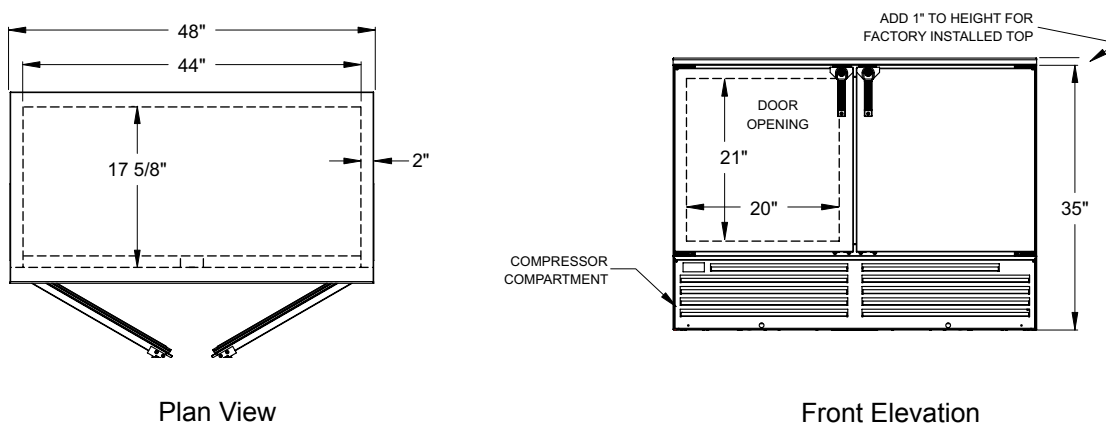

Side View All Models

