



ND60-R1-SS(RRR)



NSF standard 7 listed for open food storage

Project: _____	AIA# _____
Item #: _____ Qty: _____	SIS# _____
Model #: _____	

**Narrow Door Coolers  
Two, Three and  
Four Door Remote\***

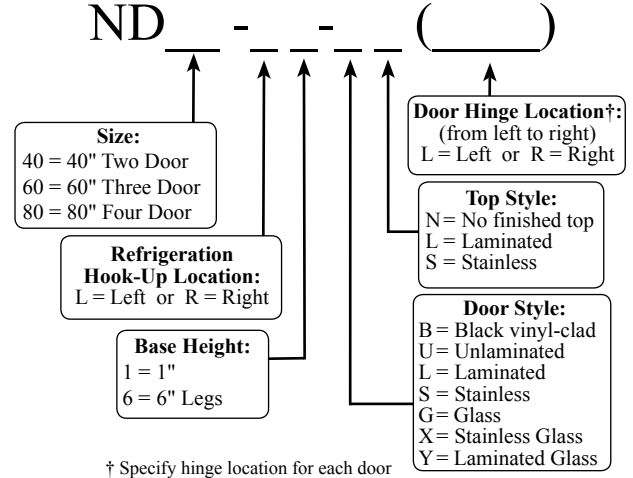

**Standard Features**

- Remote unit
- All stainless steel interior construction with radius corners for easy cleaning
- Foamed-in-place CFC free insulation
- Galvanized steel sub-top
- Black vinyl-clad steel exterior front and sides
- Stainless steel evaporator housing with separate removable evaporator drain pan
- Stainless steel die cast handle
- Leg sockets recessed into base
- 1/2" thick ABS plastic threshold scuff plate
- 180° swinging doors

**Specifications**

*Electrical*

- 120V, 1 phase, 60 Hz
- Dedicated 15 amp circuit is required
- 14 gauge wire connection is made inside the cooler next to evaporator housing - interior access is through one of the 3/4" side knock-out holes (electrician's choice)

*Refrigeration*

- R134a or R404a expansion valve & temperature control included. Specify type required when ordering.
- Recommended condensing unit:  
ND40 - 1/4 HP which has an approximate rating of 2,200 BTU/H at +20°F evaporator temperature  
ND60 and ND80 - 1/3 HP which has an approximate rating of 3,064 BTU/H at +20°F evaporator temperature
- All refrigeration hookups are made at the installation site

*Plumbing*

- A ten foot length of 1/2" ID by 5/8" OD plastic tubing is provided to drain condensate. The tubing should exit through one of the 3/4" side knock-out holes (installer's choice). The maximum drainage is one ounce per hour - consult local codes for compliance - a floor drain may be required

*Shelving*

- Two adjustable coated shelves and one bottom coated rack per door included

*Legs*

- 1-5/8" diameter
- Stainless steel bullet feet

*Materials*

- 22 gauge stainless steel parts include: interior floor, walls, ceiling, front of cabinet, and evaporator housing
- 22 gauge black vinyl-clad parts include: sides, standard doors, and compressor compartment housing
- 22 gauge galvanized steel parts include: exterior sub-top and back
- 16 gauge stainless steel parts include: legs
- 16 gauge galvanized steel parts include: base and compressor compartment base plate
- 16 gauge zinc plated CR steel parts include: leg sockets
- 12 gauge stainless steel parts include: hinges, hinge brackets, and lock brackets

\* NOTE: These units are manufactured to order. Consult the factory for pricing information

<b>Glastender, Inc.</b> • 5400 N Michigan Rd • Saginaw, MI • 48604-9780 989.752.4275 • 800.748.0423 • Fax 989.752.4444 www.glastender.com	Approval/Notes:
---	-----------------

Specifications subject to change without notice. For current specifications please visit our website.

# Remote Narrow Door Coolers

## Dimensional Information

### ND40

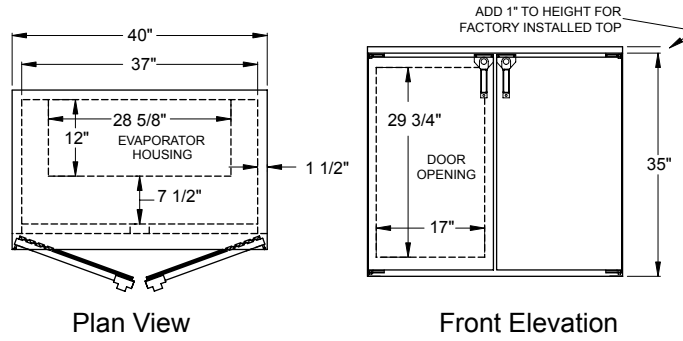

Plan View

Front Elevation

### ND60

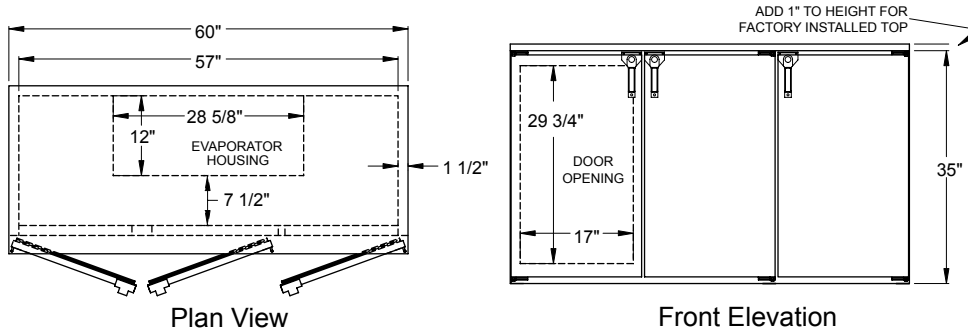

Plan View

Front Elevation

### ND80

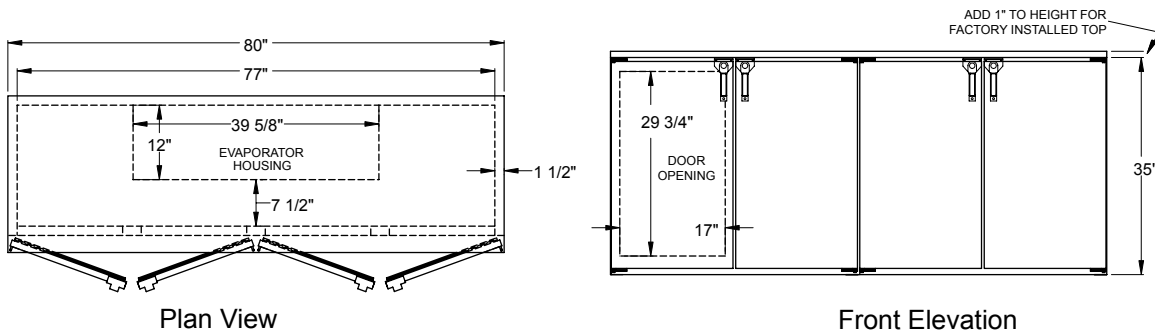

Plan View

Front Elevation

## Side View All Models

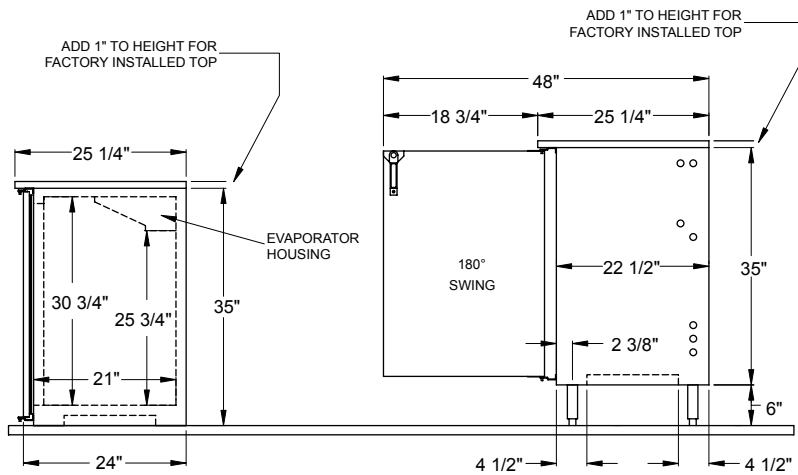

STANDARD CABINET

WITH OPTIONAL 6" LEGS

Model	Capacity: 12 oz. bottle / 1/2 barrels	Refrigeration	Voltage Required
ND40	9.8 cases / 2 half barrels	1/4 H.P. Recommended	120v / 60 Hz / 1 phase
ND60	17.25 cases / 3 half barrels	1/3 H.P. Recommended	120v / 60 Hz / 1 phase
ND80	23 cases / 4 half barrels	1/3 H.P. Recommended	120v / 60 Hz / 1 phase



5400 N Michigan Rd • Saginaw, MI • 48604-9780  
989.752.4275 • 800.748.0423 • Fax 989.752.4444  
www.glastender.com