



ND52L-GS(RL)



Intertek

4004503



Intertek

Conforms to NSF/ANSI STD 7* and UL STD 471
Certified to CSA STD C22.2 No. 120

*Door models are NSF 7 for open food storage. Units with drawers are NSF 7 for closed container products.

Project: _____	AIA# _____
Item #: _____ Qty: _____	SIS# _____
Model #: _____	

Narrow Door Coolers One, Two, Three and Four Door Self-Contained

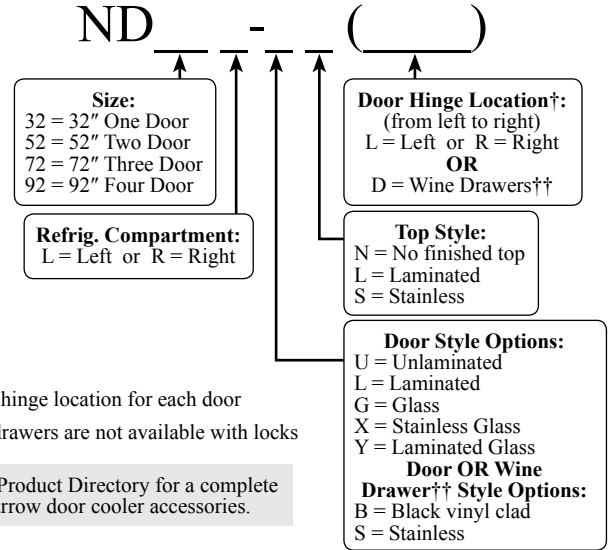

Standard Features

- DOE 2017 compliant
- All stainless steel interior with radius corners is easy to keep clean
- Locking door(s) (drawers sections do not lock)
- LED interior lighting
- Heated mullion to minimize condensation
- Evaporator above compressor compartment to maximize storage capacity
- Any door opening may be converted to a wine drawer section
- Available without a finished top for integrated installation below customer supplied bar top
- Easy to remove condenser filter can be regularly cleaned to maintain condenser coil efficiency
- 180° swinging doors

Specifications

Electrical

- 120V, 1 phase, 60 Hz
- Full load amps - ND32 - 3.0, ND52, ND72, ND92 - 5.7
- Dedicated 15 amp circuit is required
- Includes a 6 foot NEMA 5-15P grounded cord and plug which exits the back of refrigeration compartment



Refrigeration

- R134a
- Compressor - ND32 - 1/8 HP, ND52, ND72, ND92 - 1/4 HP
- Heat rejection - ND32 - 1228 BTU/Hr, ND52, ND72, ND92 - 2334 BTU/Hr

Operating Range

- 34°F (1°C) to 40°F (4°C)

Plumbing

- Automatic condensate evaporator. No drain connection required.

Shelving

- Two adjustable coated shelves and one bottom coated rack per door included (does not include wine drawer sections)

Materials

- Stainless steel parts include: interior, front of cabinet, hinges, hinge and lock brackets, and optional legs
- Black vinyl-clad steel parts include: standard sides, doors, and compressor cover
- Galvanized steel parts include: exterior sub-top, back and bottom
- Zinc plated CR steel parts include: leg sockets

Weight Bearing Capacity

- Counter tops and other accessories should not exceed 500 pounds per door

Capacities	ND32	ND52	ND72	ND92
• 12 oz. bottles, cases	5.8	13.3	21.1	28.8
• 750ml wine bottles*	57	116	188	260
• 1/2 barrel kegs will not fit through door opening				
• 1/6 barrel kegs	2	7	11	15

*Drawer units hold up to 40 wine bottles per 20" section

Glastender, Inc. • 5400 N Michigan Rd • Saginaw, MI • 48604-9780 989.752.4275 • 800.748.0423 • Fax 989.752.4444 www.glastender.com	Approval/Notes:
---	-----------------

Specifications subject to change without notice. For current specifications please visit our website.

Self-Contained Narrow Door Coolers

Dimensional Information

Model	X	Y	DOORS
ND32	32"	16"	1
ND52	52"	36"	2
ND72	72"	56"	3
ND92	92"	76"	4

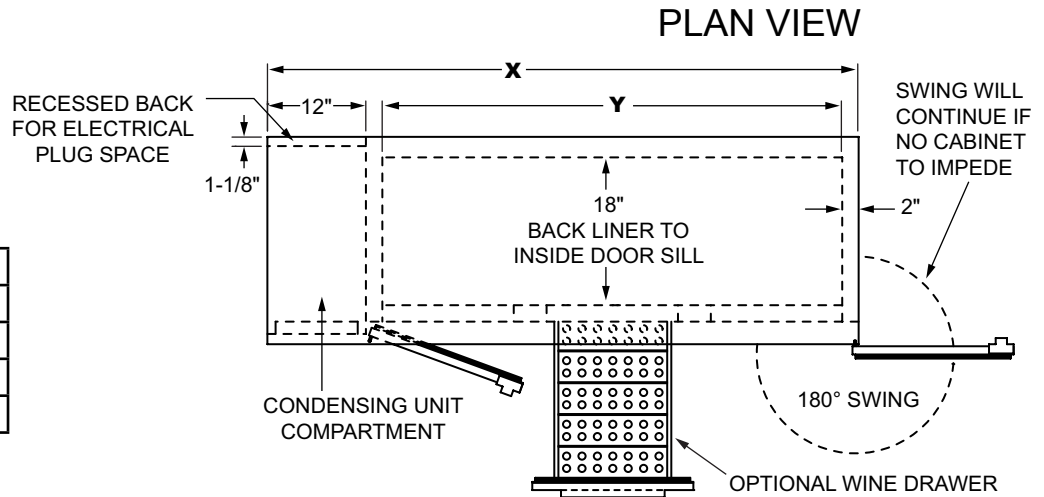

Note: Available with compressor left or right.
Compressor left model shown. Use Model Number Key to specify location when ordering.

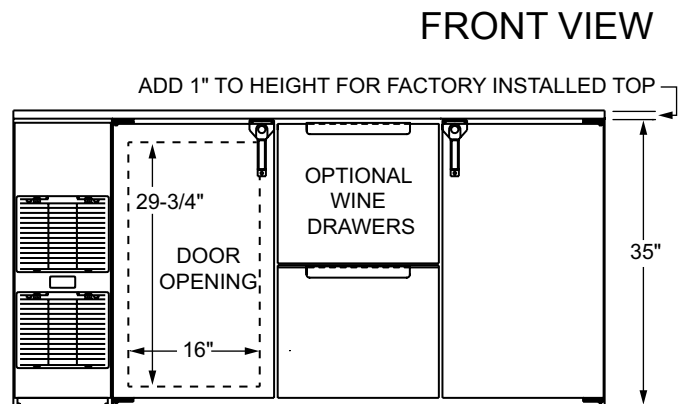

SIDE VIEWS

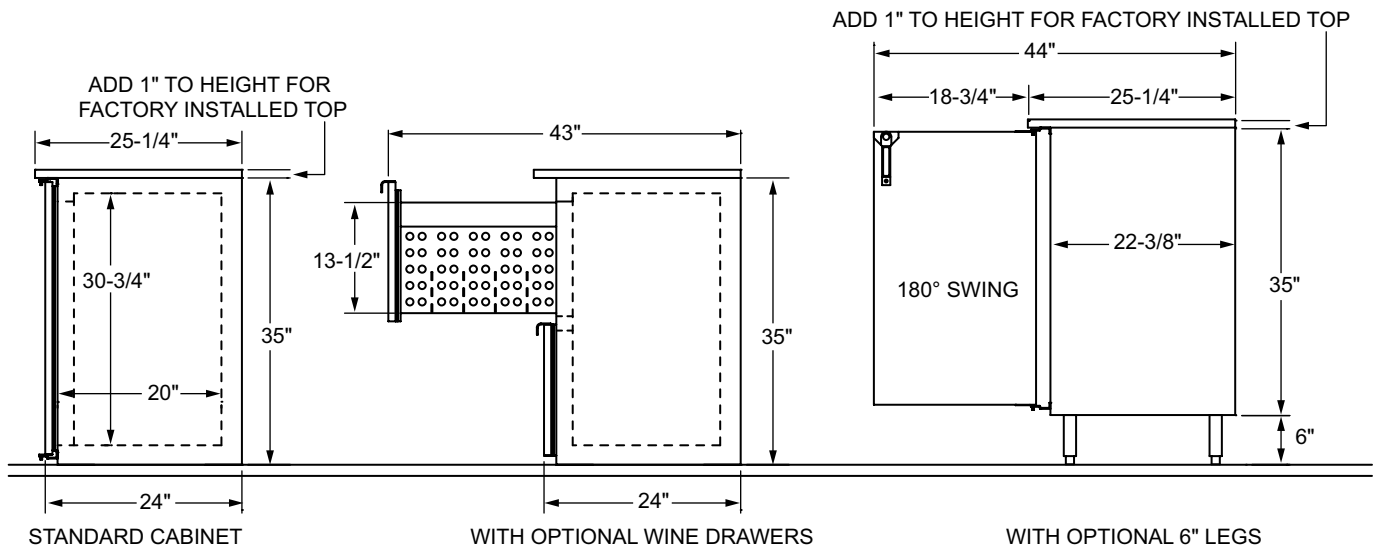

5400 N Michigan Rd • Saginaw, MI • 48604-9780
989.752.4275 • 800.748.0423 • Fax 989.752.4444
www.glastender.com

Printed in USA