



DWB-15L  
 (shown in an installation setting  
 with optional trash receptacle)

Project: _____	AIA# _____
Item #: _____ Qty: _____	SIS# _____
Model #: _____	

## Dry Waste Chutes

DWB-12, DWB-15L, DWB-15R, DWB-18

### Standard Features

- All stainless steel construction
- Top lifts up in front for easy removal of trash receptacle
- Top lifts off completely for thorough cleaning
- Matches 30" high worksurface profile of adjacent equipment
- Designed to house the Rubbermaid® Slim Jim™ trash receptacle
- Four different models to meet various installation requirements: two side mount, one-side mount or free standing



**Intertek**  
 4004503  
 Conforms to ANSI/NSF STD 2

To view underbar installation instructions, please visit: [http://www.glastender.com/PDF/F-750-165\\_Underbar\\_Installation\\_Instructions.pdf](http://www.glastender.com/PDF/F-750-165_Underbar_Installation_Instructions.pdf)  
 To view cleaning and care instructions, please visit: [http://www.glastender.com/PDF/F-423-011\\_ss\\_clean\\_care.pdf](http://www.glastender.com/PDF/F-423-011_ss_clean_care.pdf)

<b>Specifications</b>	<b>Product Information</b>
-----------------------	----------------------------

*Legs*

- 1-5/8" diameter, 16 gauge stainless steel
- Stainless steel bullet feet

*Materials*

- 20 gauge stainless steel

There are four different Dry Waste Chute models to meet various installation requirements. For all four models, the top lifts up for emptying the trash receptacle. The top also lifts off completely for more thorough cleaning. The DWB-12 is designed for mounting between two adjacent pieces of Glastender underbar. The DWB-15L and DWB-15R include a left or right side and leg set, respectively, for mounting to just one piece of Glastender underbar. The DWB-18 is free standing. All models are designed to house a Rubbermaid® Slim Jim™ trash receptacle, which is available from Glastender under part number 03000497

<p><b>Glastender, Inc.</b> • 5400 North Michigan Road • Saginaw, MI • 48604-9780                  989.752.4275 • 800.748.0423 • Fax 989.752.4444  <a href="http://www.glastender.com">www.glastender.com</a></p>	<p>Approval/Notes:</p>
<p>Specifications subject to change without notice. For current specifications please visit our website.</p>	

# Dry Waste Chutes

## Dimensional Information

DWB-12

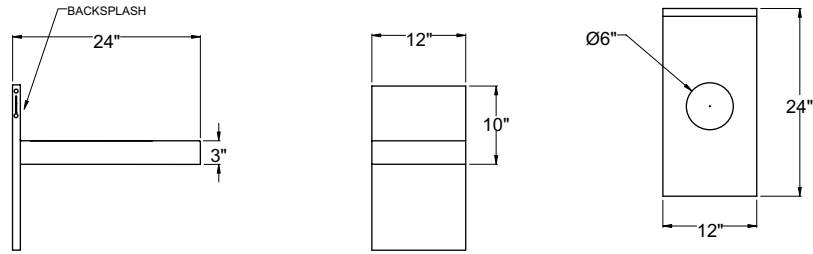

SIDE ELEVATION

FRONT ELEVATION

PLAN VIEW

DWB-15L

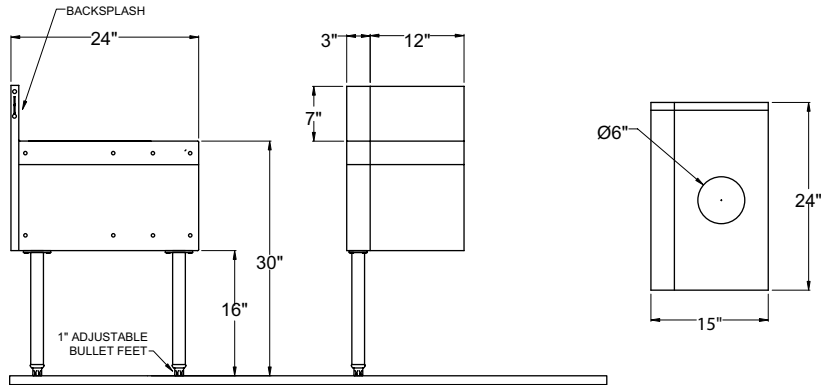

SIDE ELEVATION

FRONT ELEVATION

PLAN VIEW

DWB-15R

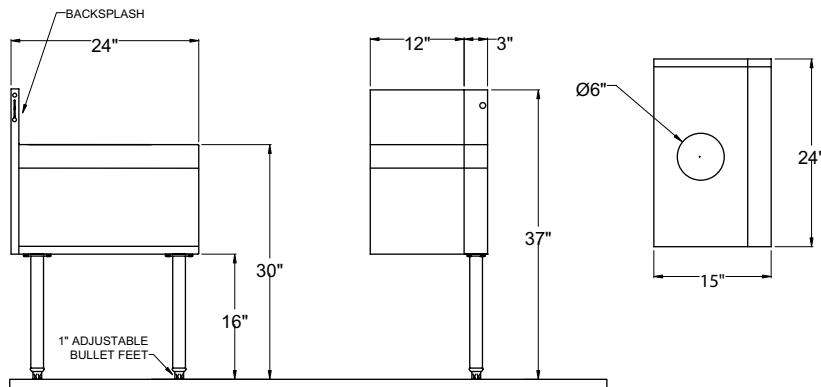

SIDE ELEVATION

FRONT ELEVATION

PLAN VIEW

DWB-18

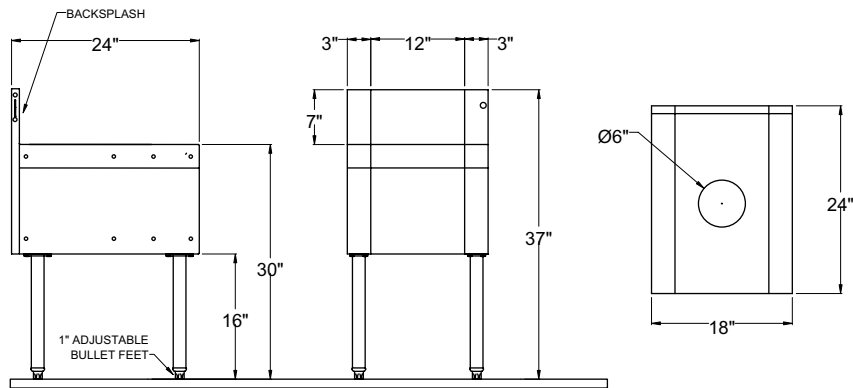

SIDE ELEVATION

FRONT ELEVATION

PLAN VIEW