

Project: _____	AIA# _____
Item #: _____ Qty: _____	SIS# _____
Model #: _____	

## 66" x 32" Complete Style Cocktail Station

CS-66x32-CW or CS-66x32-CCW

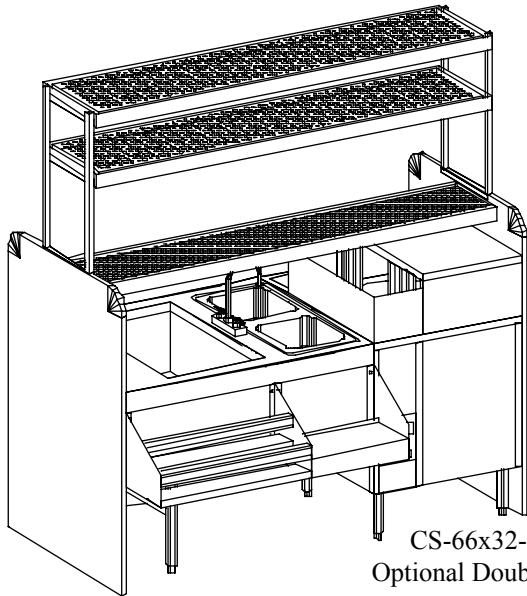

CS-66x32-CW with  
Optional Double Overshelf

**NOTE: Cocktail stations can be ordered without the laminated front and end panels for customers who wish to provide their own. Add the suffix '-S' in the model number when ordering.**

To view underbar installation instructions, please visit: [http://www.glastender.com/PDF/F-750-165\\_Underbar\\_Installation\\_Instructions.pdf](http://www.glastender.com/PDF/F-750-165_Underbar_Installation_Instructions.pdf)  
To view cleaning and care instructions, please visit: [http://www.glastender.com/PDF/F-423-011\\_ss\\_clean\\_care.pdf](http://www.glastender.com/PDF/F-423-011_ss_clean_care.pdf)

### Standard Features

- GT-24 rotary glasswasher - specify when ordering: voltage - 120/208V or 120/240V, 1 phase, 60Hz,
- Pass thru ice bin - capacity 110#
- Two wet waste sinks with strainers - dimensions: 9-1/4" by 11-1/2" by 6" deep
- Gooseneck faucet
- Removable stainless steel dry waste receptacle (12 gallon capacity)
- Stainless steel draining shelf with removable perforated inserts
- Tubing chase - dimensions: 4" by 8" by 6-1/2" high
- Double speed rail - dimensions: 24" long by 10" deep - capacity: 12 bottles
- Blender shelf - dimensions: 16" long by 10" deep
- Laminated wooden front and end panels, specify laminate manufacturer, color, and catalog number when ordering (Conversion to stainless steel front and end panels is available)
- Available in clockwise or counterclockwise rotation

### Specifications

#### GT-24 Glasswasher

- See GT-24 Glasswasher spec sheet, page 1.01 of the Specification Guide

#### Ice Bin

- 16" by 26-1/2" by 10-1/2" deep

#### Sink Bowls

- 9-1/4" by 11-1/2" by 6" deep

#### Tubing Chase

- 4" by 8" by 6-1/2" high

#### Sneeze Guard (optional)

- 17-1/4" by 27-1/2" by 10" high

#### Ice Bin Drain

- Standard model...1-1/2" tailpiece
- Ten circuit cold plate models...1/2" MPT

#### Sink Drains

- 1-1/2" I.P.S.

#### Tray and Overshelf (optional) Drains

- 1/2" tailpiece

#### Faucet

- On 4" centers, accepts 3/8" sink leads, hot and cold water connections required

#### Cold Plate

- Ten circuit available

#### Shelf Heights

- Tray shelf...44"
- Single overshelf (optional)...69"
- Double overshelf (optional)...63" and 72"



**Intertek**

4004503

Conforms to NSF/ANSI STD 2  
Certified to CSA STD B45.4

#### Rotation

- Ice bin can be at bartender's left (clockwise) or right (counterclockwise) - specify when ordering

#### Materials

- 20 and 22 gauge stainless steel parts include: glasswasher cabinet
- 20 gauge stainless steel parts include: tray shelf and inserts, tubing chase, work surface, blender shelf, double speed rail steps, bowls, and ice bin (Stainless front and end panels if specified)
- 18 gauge stainless steel parts include: glasswasher floor and tank, dry waste receptacle, leg set cross braces, and leg pads
- 16 gauge stainless steel parts include: leg mounting brackets and legs
- 14 gauge stainless steel parts include: blender shelf ends and double speed rail ends
- Laminated wooden front and end panels
- 1/4" clear acrylic sneeze guard (optional)
- Conveyor is electropolished, welded stainless steel wire

#### Recommendations

- Provide 12" by 12" open floor drain (safe waste) under ice bin - consult local codes
- Provide 120V, 20 AMP, four-plex electrical outlet below ice bin for appliances such as blenders, carbonators, dispensers, etc.

**⚠ WARNING:** The plastic wet waste strainer included with this product can expose you to chemicals including Bisphenol A (BPA), which is known to the State of California to cause birth defects or other reproductive harm. For more information, go to [www.P65Warnings.ca.gov](http://www.P65Warnings.ca.gov).  
**Warning applies to State of California only.** Part #03000483



**All faucets are NSF/ANSI 61, Annex G low lead compliant**

Glastender, Inc. • 5400 North Michigan Road • Saginaw, MI • 48604-9780  
989.752.4275 • 800.748.0423 • Fax 989.752.4444  
www.glastender.com

Approval/Notes:

Specifications subject to change without notice. For current specifications please visit our website.

# CS-66x32 Cocktail Station

## Dimensional Information

**CS-66x32-CW**  
(Clockwise Rotation)

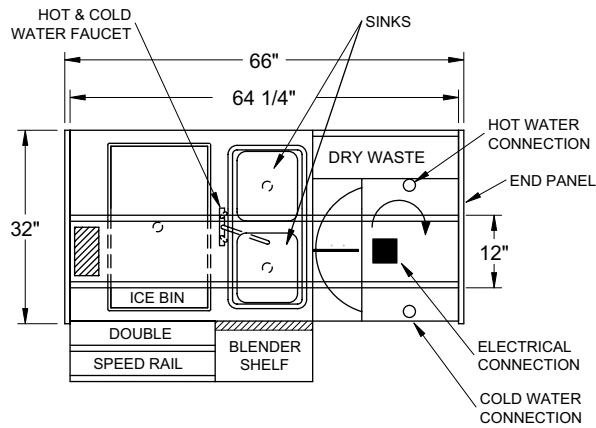

BARTENDER SIDE

PLAN VIEW

**CS-66x32-CCW**  
(Counterclockwise Rotation)

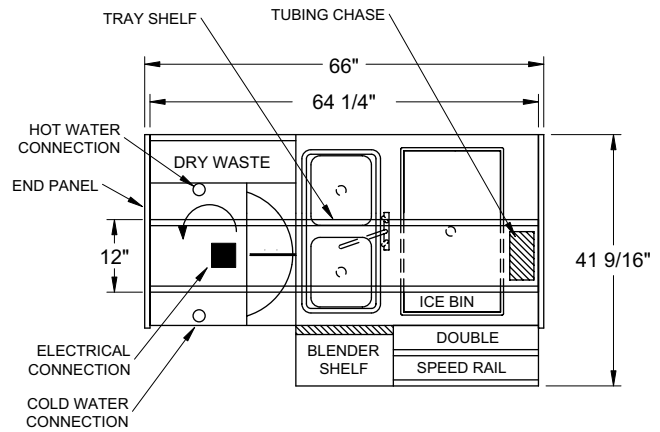

BARTENDER SIDE

PLAN VIEW

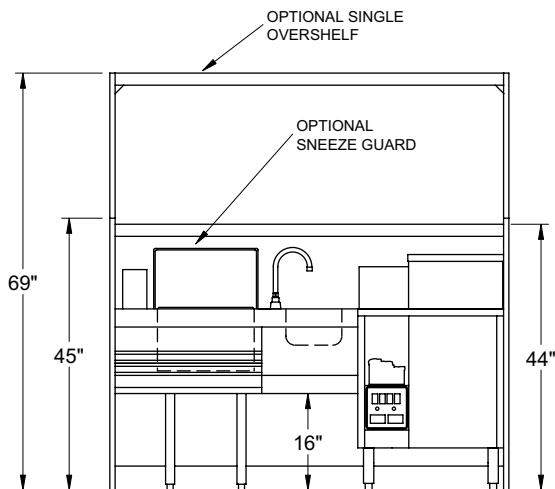

BARTENDER SIDE ELEVATION

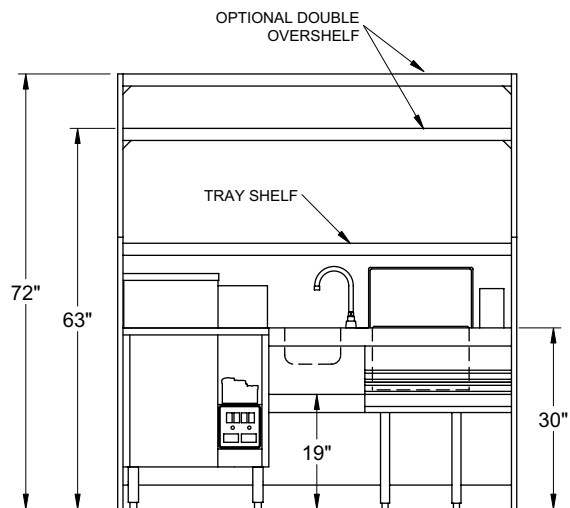

BARTENDER SIDE ELEVATION

### OPTIONAL ACCESSORIES

MODEL	DESCRIPTION
CPS-66x32	Convert laminated panels to stainless
02000626	Ten-circuit sealed cold plate
SOS/SS-66	Stainless steel single overshelf
DOS/SS-66	Stainless steel double overshelf
IBD-H-CS32	Ice bin divider, half

MODEL	DESCRIPTION
CCD/T	Clip-on condiment dispenser
03000509	Sneeze guard
CSR-16	Clip-on single speed rail
CDSR-16	Clip-on double speed rail
CDRY	Clip-on dry waste, stainless steel



5400 North Michigan Road • Saginaw, MI • 48604-9780  
989.752.4275 • 800.748.0423 • Fax 989.752.4444  
www.glastender.com

Printed in USA